

Crash Protection

Rear Impact

Protocol

Implementation January 2026

Copyright © Euro NCAP 2025 - This work is the intellectual property of Euro NCAP. Permission is granted for this material to be shared for non-commercial, educational purposes, provided that this copyright statement appears on the reproduced materials and notice is given that the copying is by permission of Euro NCAP. To disseminate otherwise or to republish requires written permission from Euro NCAP.

PREFACE

During the test preparation, vehicle manufacturers are encouraged to liaise with the laboratory and to check that they are satisfied with the way cars are set up for testing. Where a manufacturer feels that a particular item should be altered, they should ask the laboratory staff to make any necessary changes. Manufacturers are forbidden from making changes to any parameter that will influence the test, such as dummy positioning, vehicle setting, laboratory environment etc.

It is the responsibility of the test laboratory to ensure that any requested changes satisfy the requirements of Euro NCAP. Where a disagreement exists between the laboratory and manufacturer, the Euro NCAP secretariat should be informed immediately to pass final judgment. Where the laboratory staff suspect that a manufacturer has interfered with any of the set up, the manufacturer's representative should be warned that they are not allowed to do so themselves. They should also be informed that if another incident occurs, they will be asked to leave the test site.

Where there is a recurrence of the problem, the manufacturer's representative will be told to leave the test site and the Secretary General should be immediately informed. Any such incident may be reported by the Secretary General to the manufacturer and the person concerned may not be allowed to attend further Euro NCAP tests.

DISCLAIMER: Euro NCAP has taken all reasonable care to ensure that the information published in this protocol is accurate and reflects the technical decisions taken by the organisation. In the unlikely event that this protocol contains a typographical error or any other inaccuracy, Euro NCAP reserves the right to make corrections and determine the assessment and subsequent result of the affected requirement(s).

CONTENTS

SCORING	1
1 MEASURING EQUIPMENT	2
1.1 Reference system	2
1.2 BioRID UN	2
1.3 H-Point manikin	2
1.4 Sled requirements	2
1.5 Measurements and variables	2
2 TEST CONDITIONS	4
2.1 Sled preparation	4
2.2 Dummy positioning and measurement	12
2.3 Head restraint test positions	13
2.4 VUT preparation – Rear seats	24
2.5 Head restraint measurement - Rear seats	25
3 TEST PROCEDURE	33
3.1 Summary	33
4 POSTTEST ASSESSMENT & INSPECTION	40
4.1 Inspection	40
APPENDIX A HPM CALIBRATION PROCEDURE	41
APPENDIX B SLED PULSE SPECIFICATIONS	46
APPENDIX C HEAD POSITION TABLE	49
APPENDIX D HEAD RESTRAINT POSITIONS DEFINITIONS	50
APPENDIX E DISCOMFORT METRIC MEASURING DEVICE	53

SCORING

Crash Protection – Rear Impact	Total points 5
Front occupants	4
Static	1
Dynamic	3
Rear occupants	1
Static	1

Definitions used in this protocol can be found in Euro NCAP Technical Bulletin CP 001.

1 MEASURING EQUIPMENT

1.1 Reference system

The sign convention used for configuring the transducers is stated in SAE J211 (2022).

1.2 BioRID UN

The BioRID UN 50th percentile male test dummy shall be used conforming to the specification detailed in Technical Bulletin CP 301.

1.3 H-Point manikin

The H-Point manikin (HPM) shall conform to the specification and certification requirements of APPENDIX A.

1.4 Sled requirements

The target sled accelerations and pulse specifications are given in APPENDIX B.

Only reverse-acceleration sled systems are allowed for the official Euro NCAP whiplash seat assessment. Deceleration sleds are not accepted for official Euro NCAP testing due to their inherently larger variability.

Some sled motion is allowed at the initiation of the test ($T=0$). To accommodate different sled types and different relationships between sled motion and the recording of test data, test time will be indexed as described in APPENDIX B.

The sled must not brake before 300ms from $T=0$.

Test Time Indexing. To normalise the time index among sled laboratory protocols with different T-zero trigger levels, the time indexing procedure described in APPENDIX B shall be used.

1.5 Measurements and variables

1.5.1 Instrumentation general

All instrumentation used in the test shall be calibrated within at least one year before each test and should be re-calibrated if it reaches its CAC during any test.

The measurement data shall be recorded according to ISO 6487 or SAE J211/1 (2022) at a minimum sample frequency of 10kHz.

1.5.2 Sled instrumentation

If necessary, remove any data channel DC bias. Typically, the value of the average measurement over 100 samples of the quiescent data channel signal is subtracted from every test measurement.

Filter the sled acceleration to channel frequency class in accordance with Euro NCAP Technical Bulletin CP 005.

Location	Parameter	CAC
Sled	Acceleration, Ax	100g
Head to head restraint contact	Contact switch	NA

2 TEST CONDITIONS

2.1 Sled preparation

2.1.1 General information

Manufacturers will be requested to provide data listed in Technical Bulletin CP 002 prior to test preparation. The specified seat back torso angle must be the same as that used in the full scale tests. Where no information is provided, physical vehicle measurements may be used. In all cases the vehicle must be placed on level ground with no occupant load and a full tank of fuel.

Ensure that the vehicle has its spare wheel and all tools supplied on board and all tyre pressures set to manufacturer's recommendations. For vehicles with active suspension and/or automatic levelling the suspension should be set to a driving speed of 40km/h in normal running conditions as specified by the manufacturer.

All base seat setup specifications must be achieved within 0.2° and 5mm of linear tolerance, with the exception of seat belt attachments.

Euro NCAP reserves the right to refuse the sled testing of a seat where the performance of the seat or head restraint could be influenced by the vehicle environment or packaging. There should be no stiff structure in the vicinity of the head restraint that could be contacted by the head in a rear impact or that could influence the dynamic deflection of the seat back. There should be no additional support for the seat back that is not present in the sled test set-up.

Where such circumstances exist, for example with two seater roadsters, the vehicle manufacturer may be offered the opportunity to test with a body-in-white or to simulate all relevant structures on the sled set-up. The additional test costs and provision of a body-in-white shall be paid for by the manufacturer in these circumstances.

Where a bulkhead or similar structure prevents the target seat back angle from being achieved, the seat track shall be adjusted forward until the angle is achieved.

2.1.2 Triggering of active elements

The OEM shall inform the Euro NCAP Secretariat whether any active elements are fitted, and whether they would be triggered for each of the test pulses. For example, pro-active head restraints or any seatbelt pretensioners.

In advance of test preparation, the manufacturer is required to show supporting data to demonstrate that the system always triggers throughout the entire range of rear impact scenarios considered by Euro NCAP. For example, the low severity RCAR bumper test would be considered.

For each element which requires a trigger, Time to Fire (TTF) must be specified by the vehicle manufacturer for each pulse if required.

2.1.3 Seat structure reference point

In addition to the coordinate system origin determined in Section 1.1, a further seat structure reference point shall also be chosen. This is defined as a fixed point on the seat structure which stays in the same position relative to the vehicle, independent of any seat adjustment. Record

(with a photograph) the location used and ensure that this is consistent between vehicle and sled measurements for a particular seat.

For vehicle manufacturer sourced seat setups, this reference point must also be specified. Figure 1 shows an example seat reference point being the front left bolt hole, but other non-moving parts of the seat mounting structure are acceptable. The seat structure reference point shall be chosen such that the relationship of the seat to the vehicle floor can be accurately reproduced on the sled.



Figure 1: Definition of the Seat reference point.

2.1.4 Toe board

The toe board is defined as a simulated floor and toe pan, consisting of a horizontal section sufficiently large to rest the dummy's feet and connected to a section oriented 45° from the horizontal. When positioned for test, the gap between the front of the seat and rear of the toe board shall be no more than 100mm. Both surfaces shall be covered with short-piled carpet. A suitable arrangement is illustrated in Figure 2.

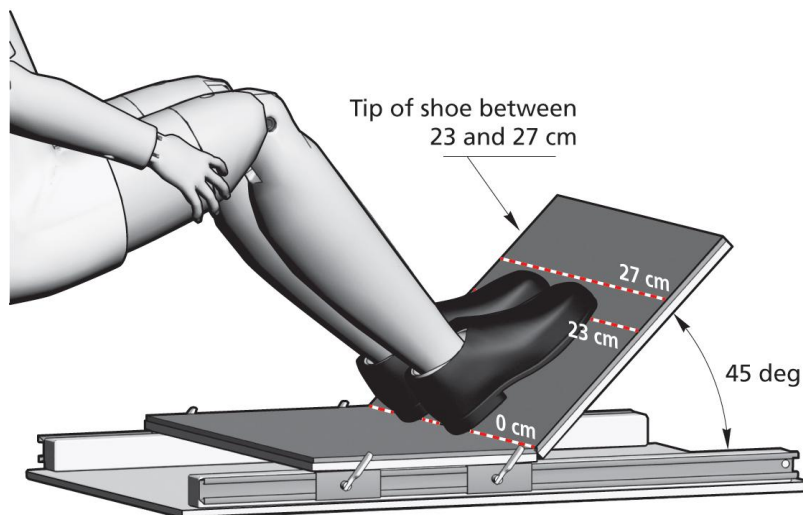

Figure 2: Toe board arrangement showing correct positioning of BioRID feet.

2.1.5 Heel surface

The heel surface is defined as the horizontal plane of the toe board (i.e. sled floor or movable footrest) on which the dummy's heel rests. Its target position is determined using the heel rest point location defined from the vehicle measurements, or from information provided by the vehicle manufacturer. An accurate height setting should be obtained at this stage; however an initial approximated horizontal position may be set. The final horizontal position will be obtained in Section 2.3.6.

Determine the heel rest point location. The heel rest point location is defined in the vehicle (with removable floor mats not fitted) by using the accelerator pedal as follows:

- Find the geometric centre point of the accelerator pedal contact surface (both laterally and vertically).
- Place a straight edge between the accelerator pedal centre point and the fixed carpeting on the vehicle floor such that the straight edge is tangential to the accelerator pedal surface at the centre point.
- The heel rest point location is then the contact point of the straight edge on the vehicle floor, see Figure 3.

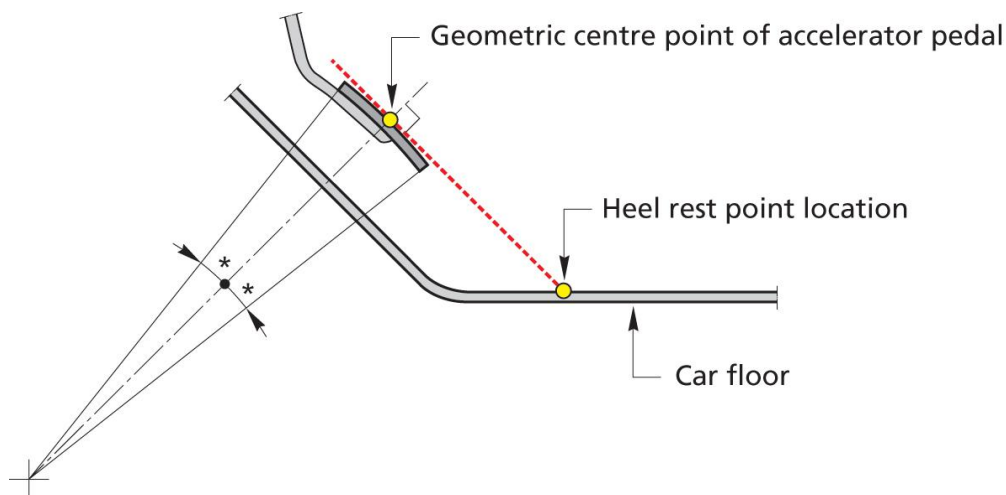

Figure 3: Heel rest point.

2.1.6 Seat mounting to sled

The seat, including all of its adjustment mechanisms and hardware that normally connects it to the vehicle floor (e.g. longitudinal adjustment rails), should be securely fastened to the test sled platform.

The attachment should be made so that the seat's orientation relative to the horizontal is the same as it would be in its vehicle as defined by physical vehicle measurements or vehicle manufacturer data. The actual height of the seat from the sled platform may be different from its height above the vehicle floor.

The toe board is also attached to the sled platform. The horizontal floor portion should be mounted at the same height relative to the seat bolts/rails as the heel rest point. The fore/aft position of the toe board should be adjustable. Figure 4 shows an example seat both in-vehicle and mounted on the sled platform.

The seat structure reference, seat rail angle and heel rest point should be recorded in the test report. Seat mounts should be rigid and non-deformable, and the seat mount interface to the seat should approximate that of the interface to the vehicle floor. The vehicle manufacturer will be asked to provide details of the relevant seat mounting measurements/tolerances and will be invited to examine the fixture prior to test. Alternatively, the car manufacturer may provide the test lab with a suitable seat attachment frame or fixture.

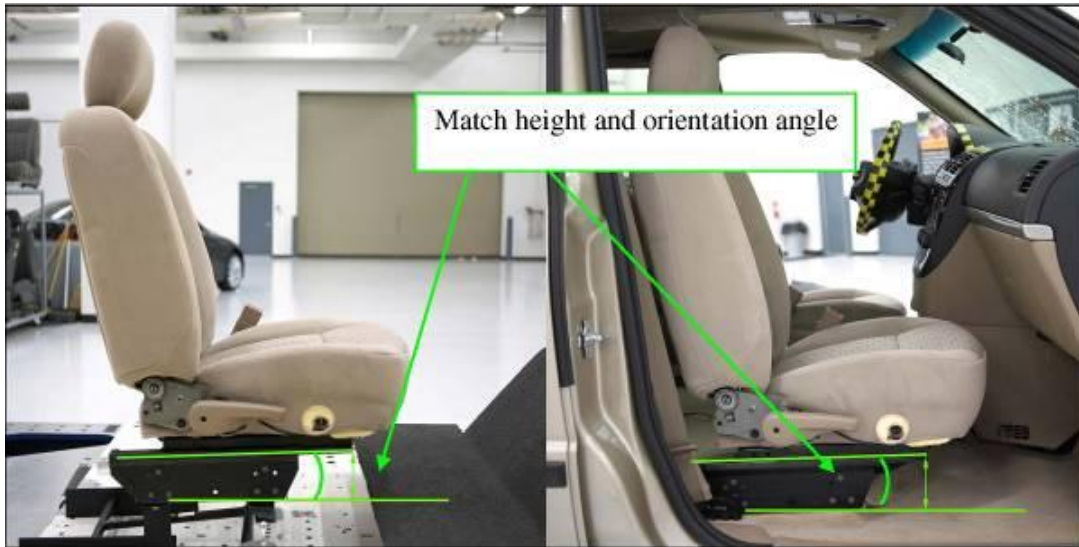

Figure 4: Attachment of seat to test sled.

2.1.7 Seat position

Seats equipped with head restraints that automatically adjust depending on other seat adjustments (e.g. seat track or height) should be set to a position most likely to be used by a 50th percentile male occupant. Therefore, the seat shall be adjusted to its mid track and mid height position.

Since the seat's starting position can affect the final position of the head restraint, a consistent setup sequence should be followed. During setting of the mid/mid position, the seat should always be moved rearward from the forward most position, and downward from the fully up position. The seatback should then be positioned following the procedure in Section 2.2. All other seat settings that have not already been adjusted shall be set as follows.

2.1.7.1 Setting manual seat adjustments.

The various seat adjustments possible on many modern vehicle seats should be set according to the following instructions. Given that the setting of some adjustments may affect the adjustment range of other adjustments, the seat shall be set by following the order of the procedure outlined here.

The seat shall have been at room temperature for at least six hours and not loaded for at least one hour prior to the initial installation of the H-point manikin. Following this pre-conditioning, the seat set up may be undertaken. The seatback angle will be set in Section 2.2, the initial setting is not important so long as it doesn't interfere with other adjustments.

Seat adjustments should now be set using the sequence described in the following parts of this

section. Subsequent seat adjustments may affect the original position of a previous setting. If this is the case, there should be no re-adjustment of the previous settings.

2.1.7.2 Initial adjustment of seat adjustment controls.

2.1.7.3 All seat controls should be set in sequence as follows. Adjustments not listed will be set to mid positions or nearest positions rearward, lowest or outboard. Technical Bulletin CP 001 provides more detailed descriptions with illustration of each of these seat adjustments.

Adjustment	Required setting – Initial positioning
Fore / aft	Fully rearward locking position
Height	Lowest position
Seat tilt	Set to the extreme of its range that puts the cushion angle closest to zero (horizontal)
Cushion height	Lowest
Cushion tilt	Set to the extreme of its range that puts the cushion angle closest to zero (horizontal)
Lumbar support	Fully retracted
Upper seat back	Where separately adjustable from the lower portion, the upper shall be rotated fully rearward.
Cushion length	Fully retracted
Side bolsters	Widest position
Arm-rests	Raised / not in use position

2.1.7.4 Measurement of cushion angle.

Locate and mark a point on the forward edge of the top surface of the seat cushion and midway between the right and left edges of the cushion. Locate, mark, and record a second point that is 400mm rearward along a line parallel to the direction of the sled movement. The cushion angle is the reading from a digital protractor sitting on the surface of the seat with the rearmost end on the rear seat mark. A suitable length protractor should be chosen such as the entire length of its underside (measurement surface) is in contact with the central panel of the seat cushion. The angle measurement should not be influenced by padding or bolstering on the front of the seat base.

Alternatively, if a coordinate measurement machine (CMM) is used to record the locations of the seat marks, then the *Sine* of the cushion angle is the difference in the Z-coordinates (in mm) of these two points (first minus second) divided by 400mm. See Figure 5.

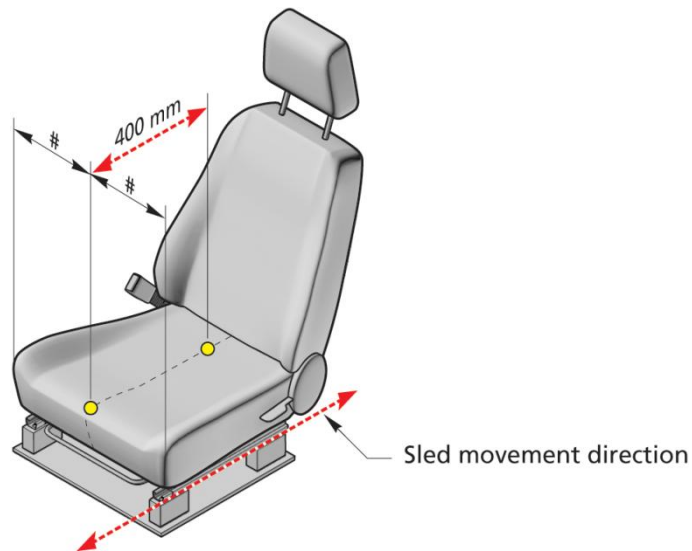

Figure 5: Measurement of cushion angle.

2.1.7.5 Setting seat track adjustment to midrange.

Mark both sides of the seat track and adjacent portion of the seat support structure. Move the seat to its most forward most locking adjustment position and mark the seat track adjacent to the repositioned marks on either side of the seat support structure. On both sides of the seat, measure the distance between the two seat track marks and mark the track midway between the first two marks.

- a) Alternatively, a CMM may be used. With the seat in the rearmost position, mark a hard point on the seat and record its location. Move the seat to its most forward adjustment position and record the position of the seat hard point.
- b) Move the seat rearward until the mark on the seat support structure aligns with centre seat track mark, or until the marked hard point is midway between the two previously recorded hard point locations. The final position will depend on whether the seat track adjusts continuously or incrementally.
- c) The seat should be checked to ensure that both seat runners are set and locked correctly. In some cases there may be different amounts of travel between the two seat runners, care should be taken to ensure that in such cases both seat runners are locked in the correct positions.

Continuously adjusting seat track. The seat mark should align ($\pm 2\text{mm}$) with the mid-track mark. Alternatively, the hard point should have an X-coordinate that is midway ($\pm 2\text{mm}$) between the X-coordinates of the forward most and rearward most adjustment positions.

Incrementally adjusting seat track. If the midrange adjustment does not correspond to an notched adjustment position ($\pm 2\text{mm}$), then the seat should be set to the first notch rearward of the calculated midrange position.

2.1.7.6 Setting seat height adjustment to midrange.

Mark two hard points on the side of the seat, which are attached to and move with the cushion frame, one near the front of the cushion and one near the rear. Record the locations of both points with a CMM or measure the vertical heights of the points relative to a fixed reference with a Euro NCAP

measuring tape. Use the seat height adjuster control(s) to move the seat to its highest position. If the front and rear of the seat adjust separately, then make sure that both the front and rear of the seat are raised to their highest positions.

Record the locations of the two hard points with the CMM or measure the vertical heights of the points relative to a fixed reference with a measuring tape. Then lower the seat until both hard points are midway between their highest and lowest positions. The final position will depend on type of seat height adjuster.

- a) Single control seat height. If the height is controlled by a single adjuster, its final position will depend on whether it is continuously or incrementally adjusting.
- b) Continuously adjusting seat height. For single control height adjusters, the rear hard point should be $\pm 2\text{mm}$ of the calculated midpoint.
- c) Incrementally adjusting seat height. If the midrange adjustment does not correspond to an indexed adjustment position ($\pm 2\text{mm}$), then the seat should be set to the first indexed position below the calculated midrange position.
- d) Dual control seat height. If the front and rear of the seat adjust separately, then use the front adjuster to lower the front hard point and the rear adjuster to lower the rear hard point. The final position will depend on whether it is continuously or incrementally adjusting. Note that the adjustment of the front and rear controls may need to be iterated in order to achieve the calculated midpoints.
- e) Continuously adjusting seat height. Both hard points should be $\pm 2\text{mm}$ of the calculated midpoints. If this is not possible, then the rear hard point should be $\pm 2\text{mm}$ of the calculated midpoint and the front hard point as close to the calculated midpoint as possible.
- f) Indexed adjusting seat height. If either midrange adjustment does not correspond to an indexed adjustment position ($\pm 2\text{mm}$), then it should be set to the first indexed position below the calculated midrange position for the corresponding seat hard point.
- g) Setting cushion height adjustment. The cushion height adjustment uses the points marked on the top surface of the cushion in the section measurement of cushion angle above.
- h) Single control cushion height adjustment. Raise the cushion to its highest adjustment and record the position of the rear cushion point (400mm behind front edge point). Lower the seat cushion to its mid-position. The final position will depend on whether it is continuously or incrementally adjusting.
- i) Continuously adjusting seats. The rear cushion point should have a Z-coordinate midway ($\pm 2\text{mm}$) between the lowest (initial) and highest positions.
- j) Incrementally adjusting seats. If the midrange adjustment does not correspond to an indexed adjustment position ($\pm 2\text{mm}$), then the seat cushion height should be set to the first indexed position below midrange.
- k) Dual control cushion height adjustment. Use the rear cushion height adjuster to raise the rear of the cushion to its highest position and record the location of the rear cushion point (400 mm behind front edge point). Again using the rear cushion height adjuster, lower the rear of the cushion so that the rear cushion point is midway between the lowest (initial) and highest positions. Use the front cushion height adjuster to raise the front of the cushion until the cushion angle matches the angle recorded earlier in this section. The final position will depend on whether it is continuously or incrementally adjusting. Note that the adjustment of the front and rear controls may need to be iterated in order to achieve the calculated midpoints.
- l) Continuously adjusting seat height. The rear seat point Z-coordinate should be $\pm 2\text{mm}$ of the calculated midpoint and the cushion angle should match that recorded in step 0 to

within ($\pm 0.5^\circ$).

- m) Indexed adjusting seat height. If the midrange adjustment of the rear adjuster does not correspond to an indexed adjustment position, then it should be set to the first indexed position below the calculated midrange. Likewise, if the cushion angle cannot be matched ($\pm 0.5^\circ$) with the front adjuster adjusted to an indexed position, then set the front adjuster to the next lowest indexed position.

Adjust the lower and upper (where present) seatback angle to conform to the design position provided by the manufacturer. This may be done with the use of identifiable 'hard points' provided by the OEM on the seat frame, head restraint tubes, recliner or similar defined structures.

If no seatback design position has been provided, adjust only the upper seatback angle to mid as detailed below.

Adjusting upper seatback angle. Measure the angle relative to vertical of the head restraint support post or some flat part of the seatback frame. Without changing the adjustment of the lower seatback, move the upper seatback to its most forward position and measure the angle of the head restraint post or seatback frame. Adjust the upper seatback rearward until the head restraint post or seatback frame angle is midway ($\pm 0.5^\circ$) between the rearmost and forward most angles.

Seat adjustments not adjusted further shall remain in the initial adjustment as set at the beginning of this section.

If the seat is new and has never been sat on, a person of mass $75\text{kg} \pm 10\text{kg}$ should sit on the seat for one minute, twice, to flex the cushions.

2.1.8 Seat belt

A generic three point lap-shoulder seat belt equipped with an inertia reel should be used during the test, placed in such a way that the belt, when worn by the ATD, should lie across the torso, clavicle and pelvis, and must always be routed above the pelvic angle gauge.

For generic seat belts, where a seat is equipped with anchorages or buckles, these may be used. Any anchorages not attached to the seat should be positioned as shown in Figure 6. The marks, which correspond to the arrangement of the anchorages, show where the ends of the belt are to be connected to the sled. The anchorages are the points A, B and K. The tolerance on the position of the anchorage points is such that each anchorage point should be situated at most at 50mm from corresponding points A, B and K indicated in Figure 6.

If a fourth anchorage is necessary to attach the retractor, this anchorage:

- a) Shall be located in the vertical longitudinal plane passing through K,
- b) Shall be located 770mm vertically below K.
- c) In the case of a belt equipped with a belt adjustment device for height, this device should be secured to a rigid frame.

The structure carrying the anchorages must be rigid and should be so constructed that no permanent deformation shall occur in the parts bearing the anchorages during the test.

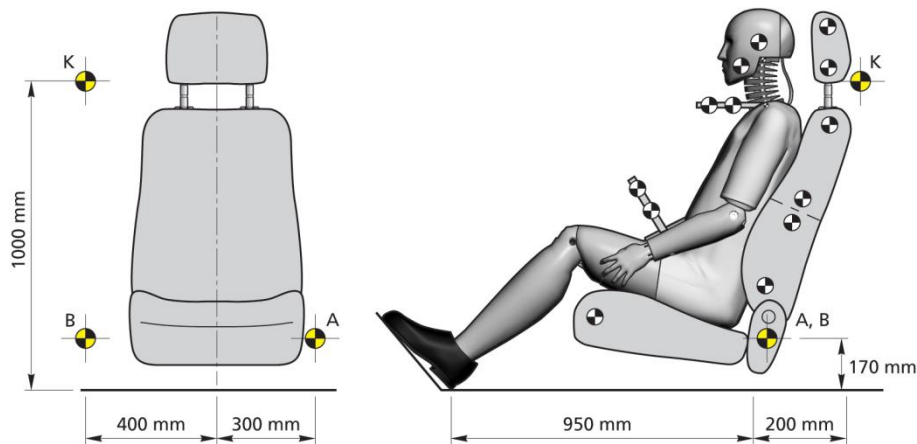

Figure 6: Generic seat belt anchorage mounting.

Where a manufacturer requests and can demonstrate good reason for doing so to the Secretariat, vehicle specific belts and geometry may be considered. In this case, or when testing seats equipped with integrated belts, the vehicles own seat belt hardware (retractor and buckle) may be used. Seat belt geometry and restraint equipment should then be used that approximates that of the test vehicle. Where this is agreed, the vehicle manufacturer will be asked to provide details of the relevant mounting measurements/tolerances and will be invited to examine the fixture prior to test. Alternatively, the car manufacturer may provide the test lab with an attachment frame or fixture.

2.2 Dummy positioning and measurement

It is the intention that the dummy is not left to sit directly on the seat for more than 2 hours prior to the test. It is acceptable for the dummy to be left in the seat for a longer period, provided that the dummy position is checked no more than one hour prior to test.

Measure the location of the H-point manikin (HPM) on all relevant seats using the procedure defined in Technical Bulletin CP 302.

Check that the measured HPM torso angle is coincident ($\pm 1^\circ$) to the manufacturer's torso design specification. If the measured HPM torso angle is outside of this tolerance, remove the manikin, make the minimal adjustments to the lower seatback angle and repeat the HPM setup.

Where no design position is provided, set the lower seatback angle to read an actual HPM torso angle of $25^\circ \pm 1^\circ$. Record the final torso angle value.

For torso design angles below 20° , testing shall be carried out at 20° . For torso design angles above 30° , testing shall be carried out at 30° .

Where the measured HPM torso angle is below 20° or over 30° , backrest shall be adjusted the minimum possible amount so the measured HPM torso angle is within the acceptable range. For seats with indexed recliner adjustments, use the closest locking position to the target torso design angle between 20° - 30° . This may require measurements in two different inclinations.

2.2.1 Record the location of the HPM H-point markers

Record the H-point positions on both sides of the HPM using a CMM or other means to record the location of both H-points relative to the seat or sled.

The H-point position on both sides of the manikin shall be within $\pm 2.5\text{mm}$ of each other in X and Z. If this is not the case, the installation procedure starting from HPM leg attachment shall be repeated.

Check that the measured H-point corresponds to the R50-point specified by the Vehicle manufacturer ($\pm 10\text{mm}$). If yes, use the R50-point specified by the Vehicle manufacturer for the calculations described in section 3.3.4. Where no R50-point specification has been provided, record and use the measured position.

2.2.2 Repeat measurements

This is only applicable if no design position for the seat back or R50-point has been provided by the manufacturer, or if the H-point does not correspond to the design position or is outside of the specified tolerances.

Remove the H-point manikin and repeat the installation two further times and record ALL measurements taken for each installation. For the repeat installations, the seat back angle should not be adjusted. However, where a change in seat back angle is required to obtain the required torso angle, the installation procedure shall be repeated until three consecutive installations have been performed which require no seat back angle adjustment.

For each individual seat, ensure that the H-point X and H-point Z are within a box of 5mm between the three sets of measurements. Outlying measurements should be investigated and repeated to achieve consistent static measurement results as necessary.

Once each individual seat has been measured three times, calculate the average H-Point position and average actual torso angle. These should be within the tolerances specified above. If the H-point is still not within tolerance, then the average measured H-point position shall be used.

2.3 Head restraint test positions

2.3.1 General

The same head restraint locking position must be used for both tests.

If any variability exists in the locking mechanism, such as different levels of friction that affect that head restraint position then the Euro NCAP Secretariat should be informed immediately. The decision of the position to be used in the tests shall be made by the Secretariat. Where there is damage to a seat which affects the test position, details should be noted by the test laboratory and provided in the test report, that seat should not be used for test.

The test position for the head restraint depends on whether it is fixed or adjustable and, if adjustable, whether the adjustments lock. Automatically adjusting head restraints are tested as if they are fixed restraints and the seat adjustments are set according to Section 2.1.7.

Non-locking adjustable head restraint. The head restraint is first adjusted to its lowest vertical adjustment position. If a non-locking tilt adjustment is available, this should then be set to the

most rearward horizontal adjustment position possible once the head restraint has been set to its lowest position.

Locking adjustable head restraints, midrange positions. The head restraint is adjusted to midrange of its vertical and/or horizontal adjustment positions. Only locking adjustments are set to the midrange positions. For example, a restraint with locking height adjustment and non-locking horizontal adjustment would be set to its midrange vertical position and most rearward horizontal position. The head restraint should first be set for the midrange vertical position. Midrange tilt position should then be set where this adjustment has locking notches.

2.3.2 Setting of mid-range height

Lowest position. Some head restraints can be lowered below the lowest locking position and in these cases the bottom of the restraint may contact the top of the seatback.

Highest position. The highest position is considered to be the highest locking position. If a restraint has a non-locking position above the highest locking position, then the highest locking position is still considered as the highest position, see Figure 7.

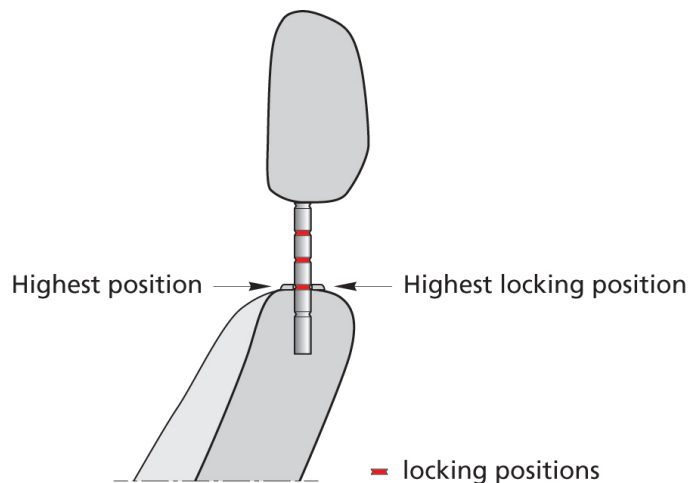

Figure 7: Examples of adjustment positions

When measuring the head restraint travel for the midrange positions, the seat must be adjusted according to Section 2.1.7, the seatback must be adjusted and HPM installed according to Section 2.2.

Mark a repeatable reference point on the top of the head restraint. This point is typically the highest point on the centreline of the head restraint. Using a coordinate measurement device, this point should first be measured in the lowest position, and then in the highest locking position without altering tilt or any other seat settings.

Midrange height position is determined by calculating the geometric mid point between the lowest position, and highest locking vertical adjustments, considering only the vertical component of measurement, see Figure 8. The test position will then be selected based on the following conditions:

- a) Place the head restraint at the geometric mid point if a locking position exists there, see Figure 8, Example A.
- b) If there is no locking position at the geometric mid point, raise the head restraint by up to 10mm. If a locking position exists within this 10mm of travel, that position will be the test position, see Figure 8, Example B.

- c) If there is no locking position within 10mm above the geometric mid point, lower the head restraint to the next lowest locking position, see Figure 8, Example C.
- d) If there is no locking position before the lowest or stowed position is reached, then the head restraint should be positioned fully down.
- e) Once the vertical test position has been determined, ensure the head restraint is returned to rearmost tilt position.

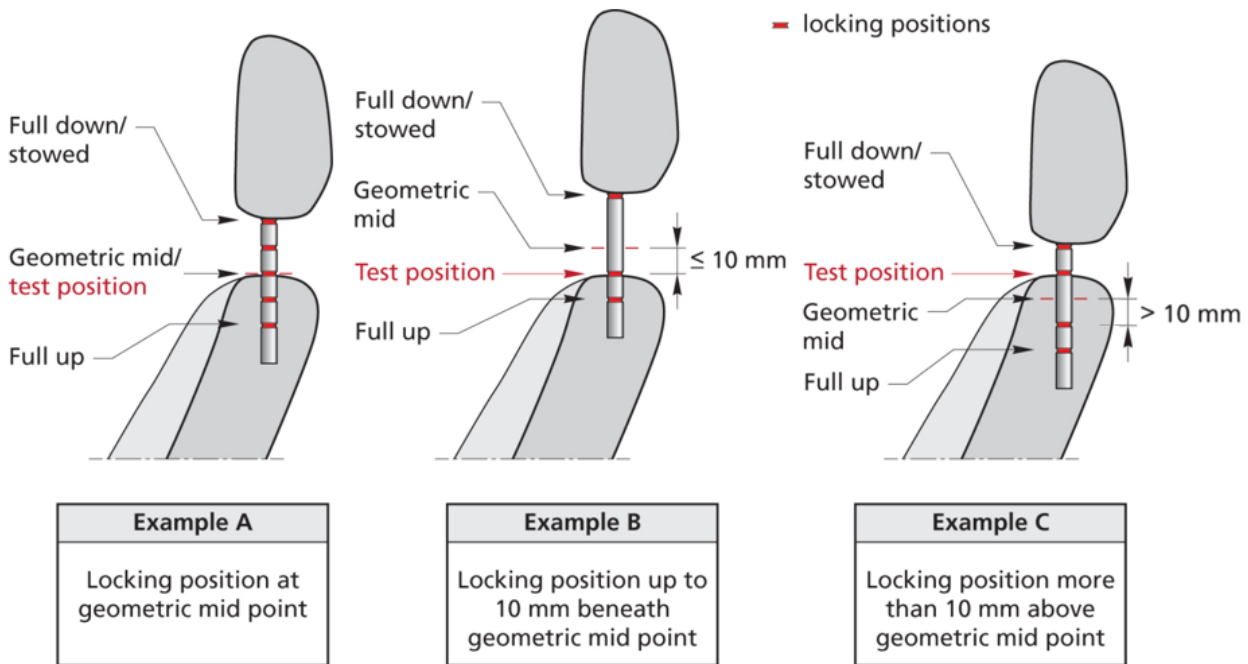

Figure 8: Examples of test position for head restraints with various locking configurations.

2.3.3 Setting of mid range tilt - locking tilt settings only

Following the setting of midrange height, the procedure should be repeated for locking horizontal adjustments. For non-locking tilt adjustments, the head restraint should be tilted fully rearward.

Most rearward tilt shall be that which results in greatest backset measurement. In the situation where the head restraint cannot be placed at most rearward tilt. For example due to a return spring, the most “most rearward tilt” shall be the most rearward position in which the tilt can be locked.

Most forward tilt shall be determined by finding the most forward locking tilt position. Non-locking positions located further forward than the most forward lock are disregarded. If no locking position exists, the head restraint should be tilted rearwards until a locking position is reached. This position shall then be considered “most forward tilt”.

Midrange tilt position is determined by calculating the geometric mid point between the most rearward tilt and most forward locking horizontal adjustments. A locking position shall be sought within a window 10mm forwards from the geometric mid point. If a lock is found within this window, that position shall be considered the test position. In the absence of a lock within this range the head restraint should be moved rearwards until the next locking position is reached. If no locking

positions are reached before the fully rearward tilt position, then fully rearward tilt shall be the test position.

2.3.4 Measure and record the head restraint geometry

Before measuring the head restraint geometry ensure that:

- a) The seat is set according to Section 2.1.7.
- b) The H-point manikin is correctly installed in the seat according to Section 2.2.
- c) The head restraint is set in the correct test position according to Section 2.3.

When measuring backset and height, a light force (e.g. 1N) should be applied, if needed, to ensure that any trim covering material is in contact with the underlying foams, or that the separation of trim material has not provided artificially favourable measurements.

All measurements shall be taken in the median longitudinal plane of the designated seating position.

Determination of contact point (CP)

Adjust the head restraint to the position determined in Section 2.3.

The CP is defined as the intersection of a horizontal line, on the height of the Z-coordinate of the back-of-head of the mid-sized male with the front surface of the head restraint as indicated in Figure 9. See APPENDIX C.

Once established, the point CP is a seat reference point (x and z coordinates), see Figure 9.

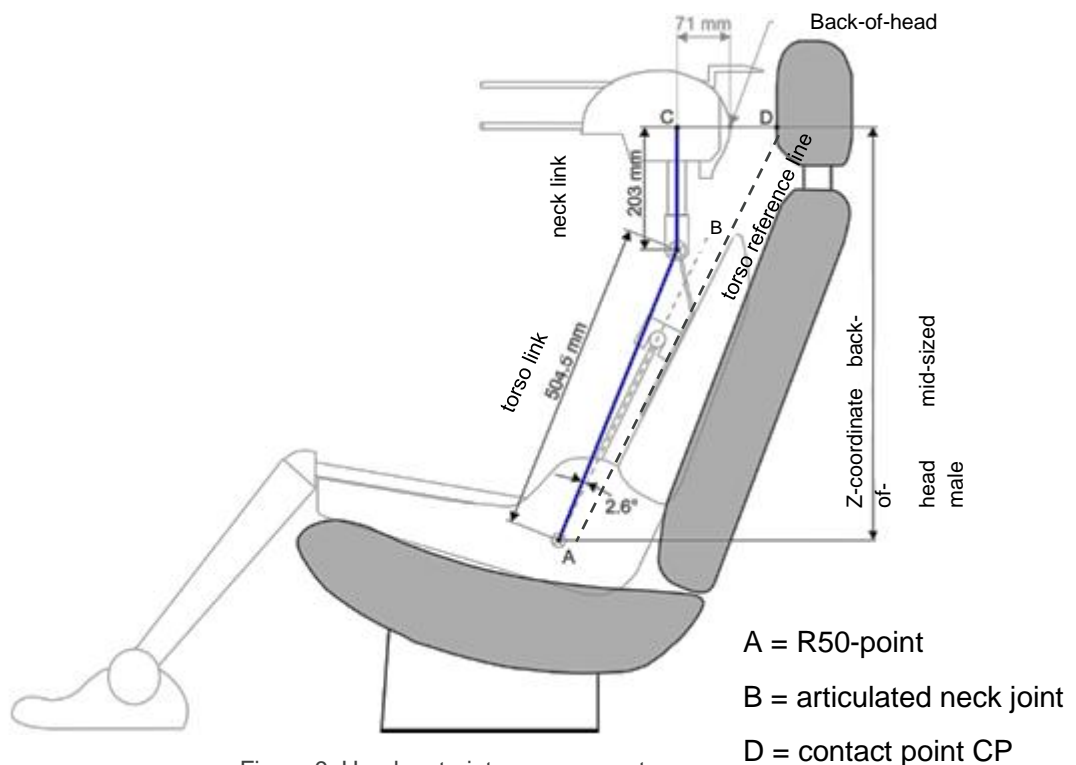

Figure 9: Head restraint measurement

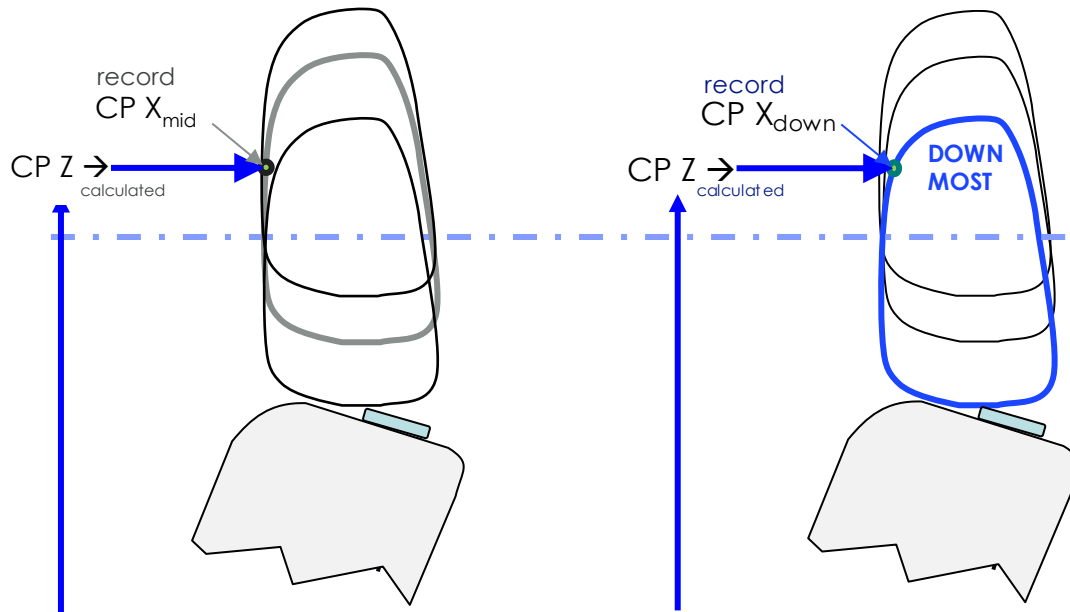

Figure 10: CP X and CP Z

Where CP cannot be determined because the horizontal line through the back-of-head of the mid-sized male is located above the head restraint, the head restraint must be raised to the next locking position to enable the determination of point CP.

In the instance where this will not produce a point of intersection, the CP will be designated at the horizontal top of the head restraint. The horizontal top of the head restraint being defined as the uppermost point on the head restraint, which is determined by lowering a horizontal line in the median longitudinal plane of the designated seating position until it touches the head restraint (see Figure 11). Where more points are located at the same height, the longitudinally forward most point of the horizontal top of the head restraint is designated as CP.

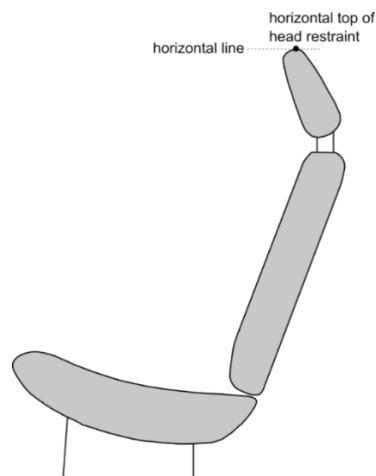

Figure 11: Determining CP

Where CP cannot be determined because the horizontal line through the back-of-head of the mid-sized male is on the level of a gap within the head restraint, CP will be determined using a 165 mm diameter sphere with its centre at the same height level as the horizontal line through the back-of-head of a mid-sized male.

When the sphere is making first contact with the head restraint, CP is designated as the rearmost point of the sphere in the gap area, see Figure 12.

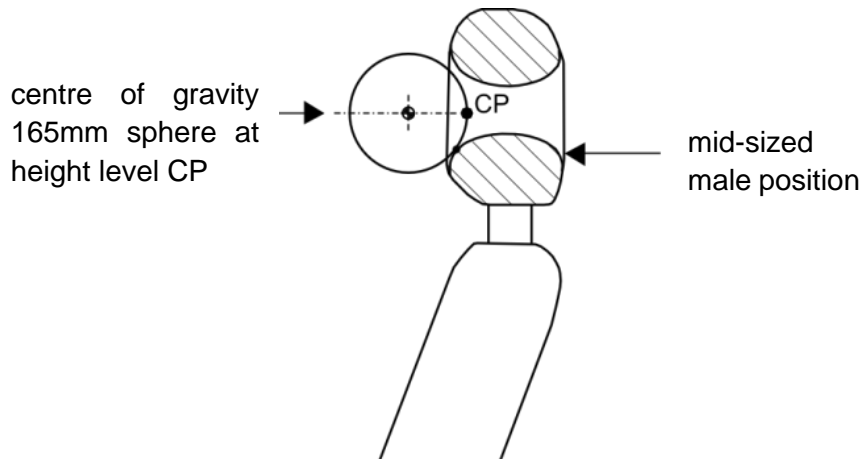

Figure 12: Determining CP

If the measured backset to point CP is negative and the head restraint has an adjustable backset, set the backset to the lowest positive backset value which can be obtained with a locking position of the head restraint. This new head restraint position will be the new test position and will be used for both dynamic tests with the BioRID.

CPx shall be measured in the head restraint test position and in the worst case position.

Determination of intersection point IP

Adjust the head restraint to the uppermost position. If the head restraint is adjustable for tilt or fore-and-aft, the tilt and fore-and-aft adjustment used for the determination of CP will be kept.

IP is determined on the front surface of the head restraint as the intersection with a vertical line rearwards of CP at the 'distance x'. See APPENDIX C. and Figure 13.

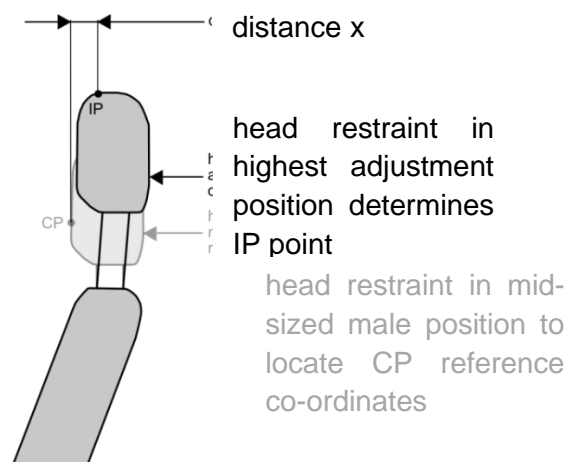

Figure 13: Determining IP

Where IP would be located rearwards of the horizontal top of the head restraint, IP will be designated at the horizontal top of the head restraint, see Figure 11.

Where the CP is designated at the horizontal top of the head restraint, and there is no existing point of IP on the head restraint surface, IP is also designated on the horizontal top of the head restraint as determined in accordance with the above. See Figure 14.

The determined point "IP" will be kept in any adjustment position.

For head restraints not adjustable for height, IP is to be determined in the fixed position.

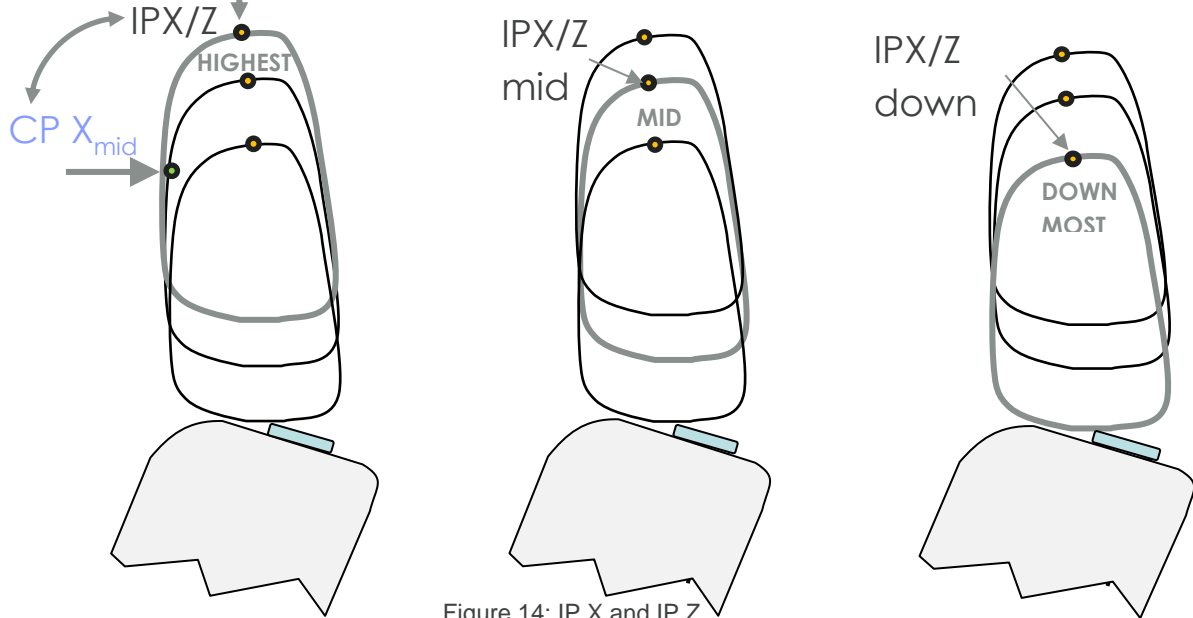

Figure 14: IP X and IP Z

For two-way adjustable head restraints (e.g. up and down only) IP shall be measured in the test and lowest positions.

For four-way adjustable head restraints (e.g. up and down plus fore and aft) IP shall be measured in the following positions:

- a) Mid vertical position & mid fore/aft
- b) Lowest vertical position (including where there is no lock) & fully rearward

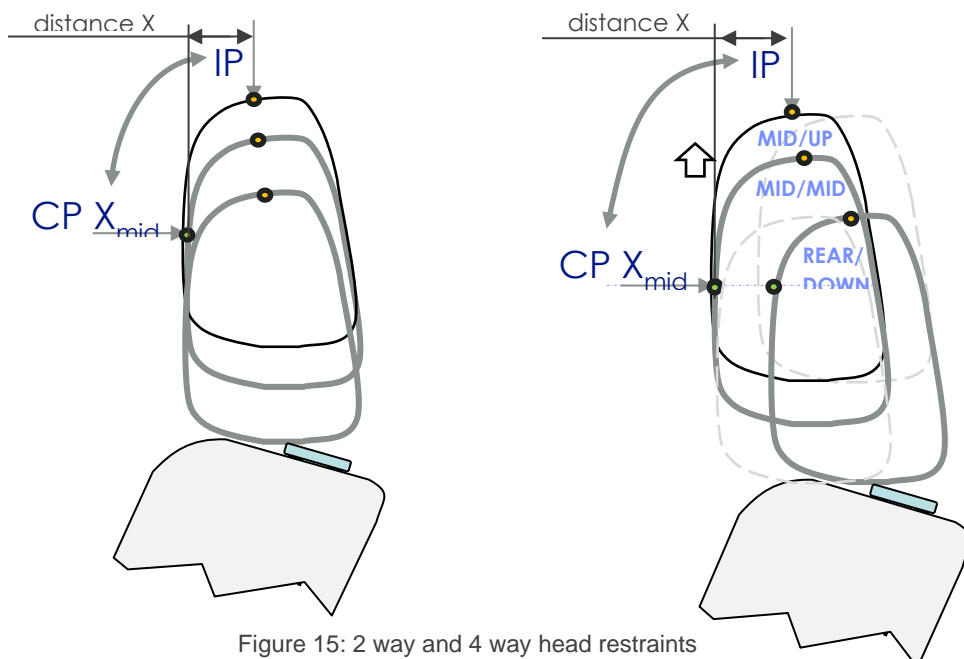

Figure 15: 2 way and 4 way head restraints

Determination of the highest head restraint height

The head restraint height is the distance from the R50-point, parallel to the torso reference line and limited by a line perpendicular to the torso reference line intersecting IP, see Figure 16.

After the coordinates of IP are determined, the head restraint height for each position to be assessed can be calculated by its longitudinal (ΔX) and vertical (ΔZ) distance from the R50-point (see Figure 16), as follows:

Head restraint height = $\Delta X \cdot \text{SIN}(\text{design torso angle}) + \Delta Z \cdot \text{COS}(\text{design torso angle})$

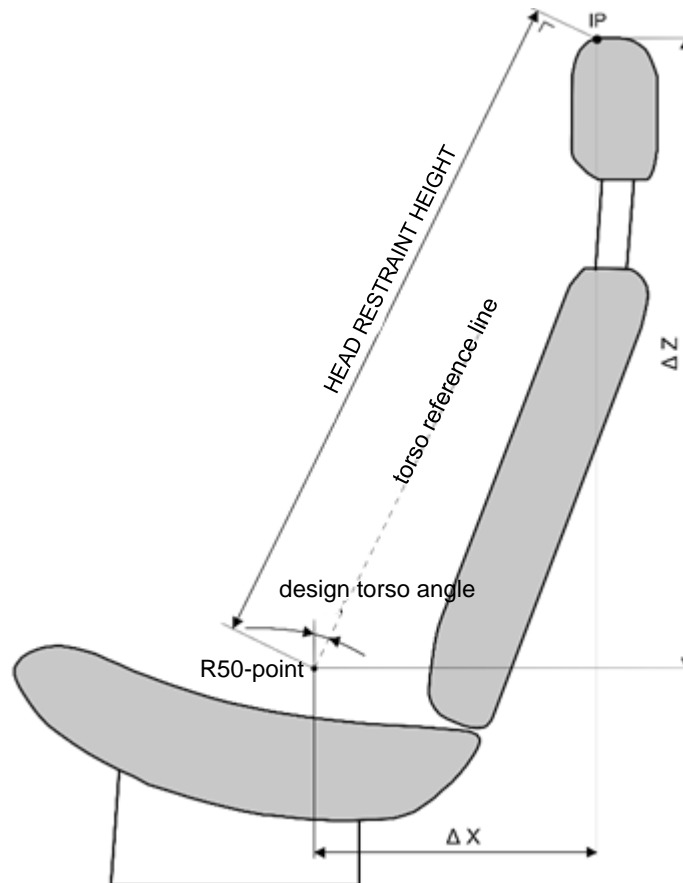

Figure 16: Head restraint height

Return the HR to the test position and measure IP X test position for effective height calculation and in the worst case position (lowest/most rearward).

2.3.5 Measure and record reference geometry for BioRID Setup.

Back of the head reference position

The theoretical back of the head reference position for the BioRID UN, used to determine the reference backset, is the value determined for the 50th percentile in APPENDIX C with reference to the specified torso angle minus 15 mm (increasing the backset as shown in Figure 17).

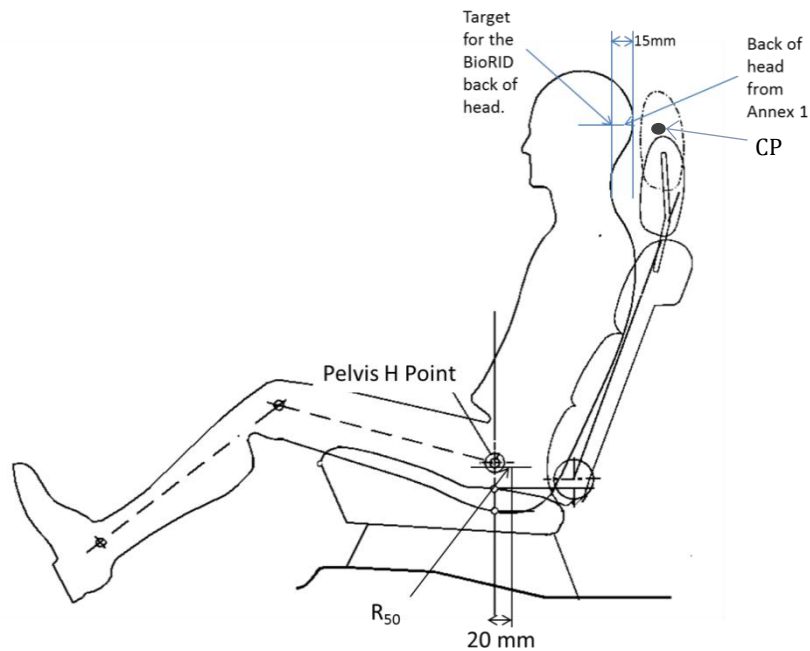

Figure 17: Measuring BioRID reference backset.

2.3.6 Install BioRID

The seat should have already been set to the required angle measured on the H-point manikin as described in Section 2.2. Allow the seat to recover for 15 minutes with nothing in it before installing the BioRID.

BioRID handling should only be undertaken using dedicated lifting tools and associated locations on the dummy following the BioRID manufacturer recommendations. Typically, during the installation of BioRID the H-point will initially be installed further rearward in the seat than is required. Therefore, the pelvis should be moved forward to achieve the target set-up positioning.

Carefully place the seat belt across the dummy and lock as normal, ensure there is sufficient slack in the belt to allow positioning of BioRID.

Align BioRID's midsagittal plane with the centreline of the seat.

Adjust BioRID's midsagittal plane to be vertical; the instrumentation platform in the head should be laterally level.

Adjust the pelvis angle to the design torso angle plus $+1.5^\circ \pm 2.5^\circ$.

Position the H-Point 20mm forward (± 10 mm) and at the same Z-height (± 10 mm) as the location recorded in Section 2.2.1 or 2.2.2, while keeping the pelvis angle within the range specified above. It is recommended to aim to set the ATD as close as possible to the nominal target values, and that the tolerance window should only be used if there is an issue achieving the required H-Point target or backset value. However, where it is not possible to position the H-point with the specified tolerance, position the H-Point close as possible to the nominal target values.

The BioRID setup tolerances are summarised below.

Adjust the spacing of the legs so that the centreline of the knees and ankles is 200mm (± 10 mm) apart and ensure that the knees are level using an inclinometer or bubble gauge.

Adjust the dummy's feet so that the heel of BioRID's shoe is resting on the heel surface. The tip of the shoe shall rest on the toe pan between 230mm and 270mm from the intersection of the heel surface and toe board, as measured along the surface of the toe board. Figure 2 shows proper positioning of the feet. Note, the heel point from a vehicle is not replicated, only heel plane height is set according to vehicle geometry.

Position the BioRID's arms so that the upper arms are as close to the torso sides as possible. The rear of the upper arms should contact the seatback, and the elbows should be bent so that the small fingers of both hands are in contact with the top of the vehicle seat cushion with the palms facing the dummy's thighs. The arms may be used to stabilise the dummy posture if needed, for example with steep seat back angles, once the torso has been pushed rearwards to achieve the required backset.

Level the instrumentation plane of the head (front/rear and left/right directions) to within $\pm 1^\circ$. Electronic tilt sensors shall be used to perform this check.

If the BioRID measured backset is different from the BioRID reference, then do the following:

- a) Tip the head fore/aft no more than 3.5° fore / 1° aft from level in order to meet the backset requirement.
- b) If the BioRID backset cannot be brought closer to the BioRID reference backset ± 5 mm by step a), adjust the pelvis angle and H-point position within their respective tolerance bands. In this case begin again with pelvis and torso angle adjustment above reposition the BioRID accordingly.
- c) If the BioRID backset cannot be brought closer to the BioRID reference position after adjustment of the head angle as specified above and if it is still not possible to set the test dummy backset measurement to within 15 ± 5 mm of the Back of the Head reference position, then the dummy's pelvis angle and the H-point position shall be adjusted within their respective tolerance bands while prioritising the adjustment of the pelvis angle tolerance to achieve correct backset. It is not permitted to achieve the required position by pushing the dummy rearward, resulting in pre-loading of the BioRID, but the arms may be used to stabilise the torso.

Where it is not possible to position the dummy in accordance with all four tolerances, prioritise the dummy positions as detailed in the BioRID setup summary table below. I.e. highest priority is given to the backset and lowest priority to the pelvic angle.

Remove the slack from the lap section of the webbing until it is resting gently around the pelvis of the dummy. Only minimal force should be applied to the webbing when removing the slack. The route of the lap belt should be as natural as possible and must be above the pelvic angle gauge.

Place one finger behind the diagonal section of the webbing at the height of the dummy sternum. Pull the webbing away from the chest horizontally forward and allow it to retract in the direction of the D-loop using only the force provided by the retractor mechanism. Repeat this step three times, only.

Once the belt is positioned the location of the belt should be marked across the dummy chest to ensure that no further adjustments are made.

BioRID setup summary.

Location	Target measure	Tolerance
Backset	15mm forward*	±5mm
H-point – x-axis	+20mm forward**	±10mm
H-point – z-axis	0mm**	±10mm
Head plane angle	0° level	±1.0° 3.5° fore / -1.0° aft
Pelvis angle	Torso design angle +1.5°	±2.5°

* Reference measurements taken in accordance with Section 2.3.5.

**Reference taken in accordance with Section 2.2.1.

2.4 VUT preparation – Rear seats

Before assessment, the manufacturer will be asked to provide ride heights for the vehicle in the unladen kerb state.

2.4.1 Vehicle preparation

If the vehicle is equipped with a foldable roof, sunroof, sunroof blind, position to the closed position. Retract any rear glazing blinds.

Do not remove floor mats when fitted as standard.

Set all first row seats fully forward and into the highest position.

Ensure that the differences between ride-heights are the same as those provided by the manufacturer. The absolute values of ride-heights do not matter.

Make sure the vehicle is stable by supporting the vehicle on the jacking points as shown in the vehicle handbook.

2.4.2 Second and third row seating setup

The manufacturer will be asked to provide seat adjustment information before the assessment is done, this information does not need to be in the vehicle handbook. Set all seat adjustments to the positions specified by the manufacturer for a 50th percentile occupant.

Where the manufacturer has not provided seat adjustment specifications, or for particular adjustments where no specifications have been provided, set the seat using all or some of steps identified below. See also APPENDIX D for details of how to set head restraint positions.

For third row assessments, set all second row seats into their fully forward and highest position if possible.

Adjustment	Required setting
Fore / aft	Fully rearward locking position
Height	Lowest position
Seat back angle	Nominal HPM torso angle of 25°.
Seat tilt	Mid position
Cushion height	Lowest
Cushion tilt	Mid position
Lumbar support	Fully retracted
Upper seat back	Where separately adjustable from the lower portion, the upper shall be rotated fully rearward
Cushion length	Fully retracted
Side bolsters	Widest position

Head restraint	Height: As per Section 2.5.4 Fore/aft or tilt: As per Section 2.5.4
Arm-rests	Raised / not in use position

2.5 Head restraint measurement - Rear seats

2.5.1 Determination of seat centreline C/LO

Refer to manufacturer specifications for the C/LO.

If manufacturer specifications are not available, find C/LO as follows:

For seats with defined bolsters, or individual auxiliary seats, C/LO is the centreline of the seat.

For bench seats (or other) seats, C/LO is the middle of the head restraint. If a head restraint is not fitted, find C/LO between the belt anchors.

If the C/LO cannot be found with the procedures above, the C/LO shall be located 381mm outboard from the vehicle centreline.

2.5.2 H-Point installation

Measure the location of the H-point manikin on all relevant seats using the procedure defined in Technical Bulletin CP 302.

2.5.3 HPM measurement

All CMM measurements are relative to the manufacturer specified car alignment coordinate system or a suitable Cartesian coordinate system if not specified. Record all measurements to 0.1mm precision. For the purposes of this protocol the X-Axis is positive rearward and the Z-Axis is positive upward.

With a CMM or other means measure and record the X, Y and Z-coordinates for the left and right H-points.

Compare the left hand and right hand X and Z-coordinates. If the related X and Z-coordinates are not within 5.0mm of each other repeat the H-point manikin installation.

Measure and record the torso angle in the vehicle XZ-plane on the calibrated block attached to the weight hanger bar to 0.1 degree precision.

Repeat the H-point manikin installation two more times.

Calculate the average for the three HPM installations measurements (HPM H-point coordinates and torso angle). Record these values.

If the average values recorded in the sentence above are within the following tolerances of the manufacturer specified values:

Torso angle: $\pm 3^\circ$

HPM X and Z: $\pm 25\text{mm}$,

then the manufacturer-defined values shall be used in all subsequent calculations. Otherwise, the recorded average values shall be used.

2.5.4 Head restraint measurement

Contact Point and Backset

In this section, the distance between the head restraint and the back of the 50th percentile male head (backset) is determined at two head restraint positions: mid position and worst case (lowest and most rearward). The backset and contact point (CP) in the mid position is subsequently used as part of the determination of the intersection point (IP).

Mark a line showing the C/LO $\pm 5\text{mm}$ along the A-Surface of the head restraint.

Using the values of torso angle and H point determined in section 2.5.3, calculate the Contact Point Z-coordinate, CP Z, which represents the height of the rearmost point of the head of a 50th percentile male.

$$CP\ Z = 504.5 \cos(\text{Torso Angle} - 2.6) + 203 + HPM\ Z$$

Set the head restraint to the mid position (see definitions and Annex A). For head restraints with locking tilt positions, it will be necessary to mark and measure CP with the restraint in the most forward and most rearward positions in order to find its location and coordinates with the head restraint in the mid-tilt position.

Use a CMM or other means to mark the CP Z-coordinate ($\pm 2.5\text{mm}$) on the C/LO line. This point is known as the Contact Point, CP.

- a) If the CP Z-coordinate cannot be marked on the A-Surface of the head restraint (because the head restraint is below the CP Z-coordinate), record the CP Z-coordinate as the highest point on the C/LO line. If more than one point is at the highest point record the most forward point.
- b) If the CP Z-coordinate cannot be marked on the A-Surface of the head restraint as the CP Z-coordinate relates to a gap in the head restraint, CP will be determined using a 165mm diameter sphere with its centre at the same height as the CP Z-coordinate. When the sphere is making first contact with the head restraint, CP is designated as the rearmost point of the sphere in the gap area, see Figure 18.

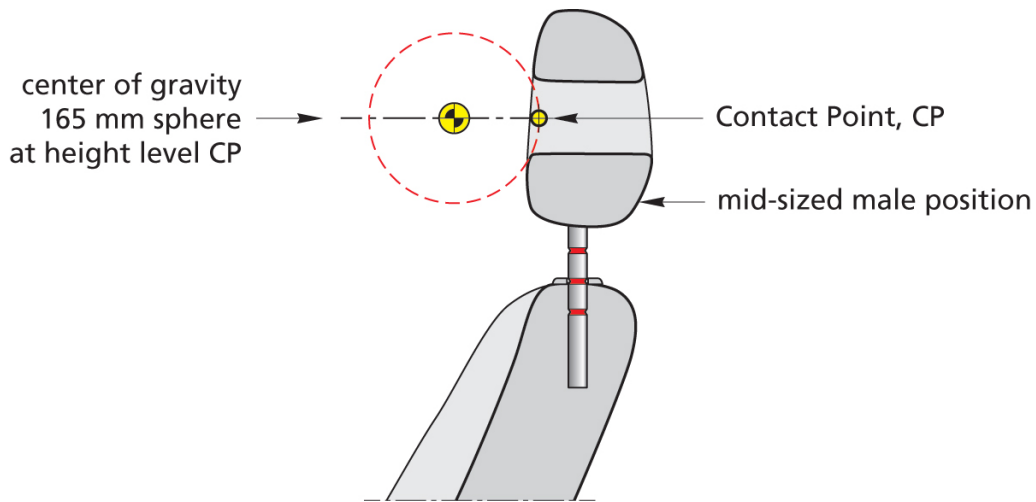

Figure 18: Definition of CP when there is a gap in the head restraint.

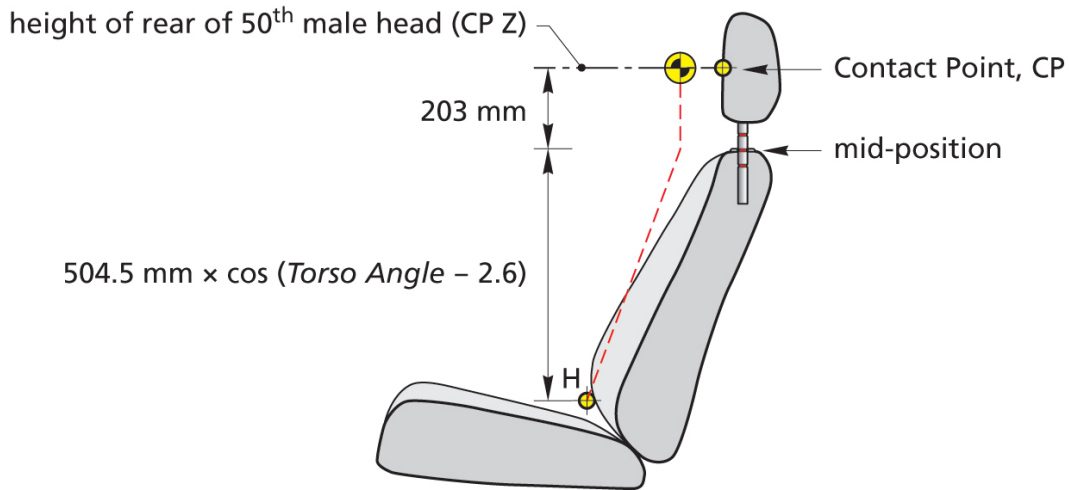

Figure 19: Contact Point.

Record the X-coordinate of the Contact Point. Record this as (CP X).

Calculate the CP X-coordinate relative to the HPM X-coordinate, $(\Delta CP X)_{mid}$.

$$(\Delta CP X)_{mid} = CP X_{mid} - HPM X$$

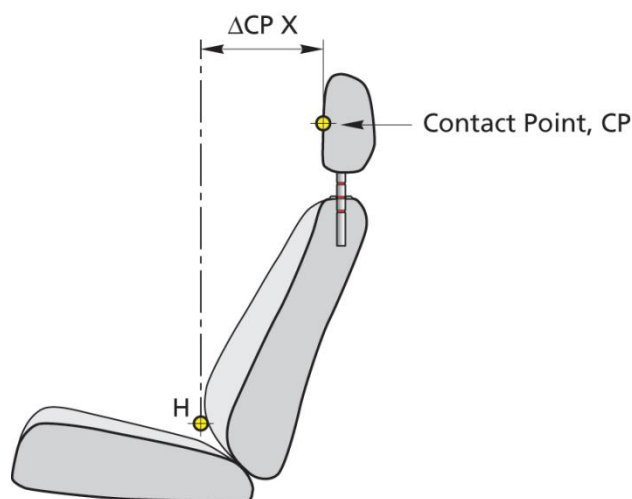

Figure 20: Calculation of Backset.

Set the head restraint to the Lowest Use and most rearward position (see definitions and Annex A).

Repeat steps marking CP Z-coordinate on the C/LO line and calculating CP X-coordinate relative to HPM X-coordinate to calculate $(\Delta CP X)_{wc}$

$$(\Delta CP X)_{wc} = CP X_{wc} - HPM X$$

2.5.5 Intersection point

Here, the 'Intersection Point' is established. To do this, the position of the contact point CP_{mid} is extended rearward by a distance corresponding to the difference between the rearmost point of a 50th percentile male and a 95th percentile male. The point on the restraint corresponding to this X coordinate is marked as IP on the head restraint, when the restraint is in its highest position.

Calculate the Intersection Point X-coordinate, IP X, which represents the additional distance in X between the back of the head of a 50th percentile male and a 95th percentile male.

$$IP X = 88.5 \cdot \sin(Torso Angle_{(0)} - 2.6) + 5 + CP X_{(0)}$$

a) This formula derives from the subtraction of two goniometric formulae which, respectively, give the X position of the back of the head of a large male and that of a mid-sized male:

$$\begin{aligned} & (593 \cdot \sin(Torso Angle - 2.6) + 76) - (504.5 \cdot \sin(Torso Angle - 2.6) + 71) \\ & = 88.5 \cdot \sin(Torso Angle - 2.6) + 5 \end{aligned}$$

Place the head restraint in the Highest Use and mid-tilt position, see definitions and APPENDIX D.

On the surface given by the C/LO line, find the highest point and record the related X-coordinate.

Figure 21: Intersection Point.
 $IP\ X = 88.5\ \text{mm} \times \sin(\text{Torso Angle} - 2.6) + 5\ \text{mm}$

IP X is the difference between the rearmost position of the 50th %ile male head and the 95th %ile male head.

The position corresponding to that X is marked on the head restraint as IP, when the restraint is set in its highest position.

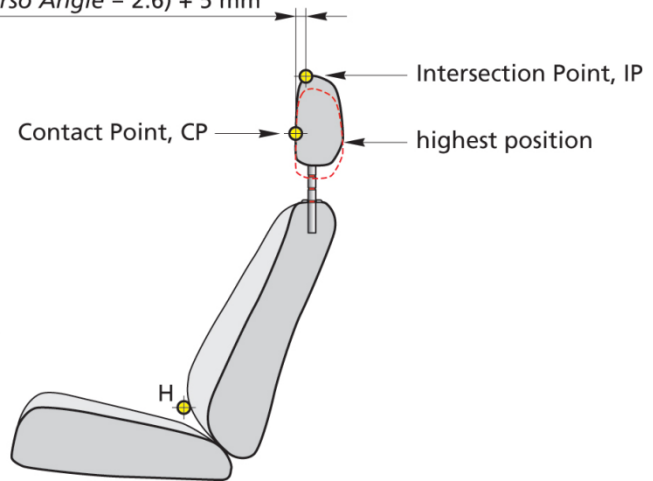

Use a CMM or other means to mark the IP X-coordinate ($\pm 2.5\text{mm}$) on the C/LO line. If the IP X-coordinate is rearward of the X-coordinate value, record the X-coordinate as IP X.

On the surface given by the C/LO line and the IP X point, record the Z-coordinate of the IP X mark. Record this point as Intersection Point Z (IP Z).

Calculate the IP X-coordinate relative to the HPM X-coordinate, $(\Delta IP\ X)_{high}$.

$$(\Delta IP\ X)_{high} = IP\ X - HPM\ X$$

Calculate the IP Z-coordinate relative to the HPM Z-coordinate, $(\Delta IP\ Z)_{high}$.

2.5.5.1 $(\Delta IP\ Z)_{high} = IP\ Z - HPM\ Z$

Place the head restraint in the Lowest Use and most rearward position, see definitions and APPENDIX D.

Using the IP-point marked earlier for all relevant head restraint positions, calculate $\Delta IP\ X$ and $\Delta IP\ Z$ for this head restraint position and record as $(\Delta IP\ X)_{wc}$ and $(\Delta IP\ Z)_{wc}$

2.5.6 Effective height

In this section, the effective height of the Intersection Point is determined in the highest and in the worst-case (lowest and most rearward) head restraint positions.

Calculate the Effective Height for the highest and for the worst-case (lowest, most rearward) in-use positions, using the appropriate values determined in the previous sections.

$$\text{Effective Height} = (\Delta IP\ X) \cdot \sin(\text{Torso Angle}) + (\Delta IP\ Z) \cdot \cos(\text{Torso Angle})$$

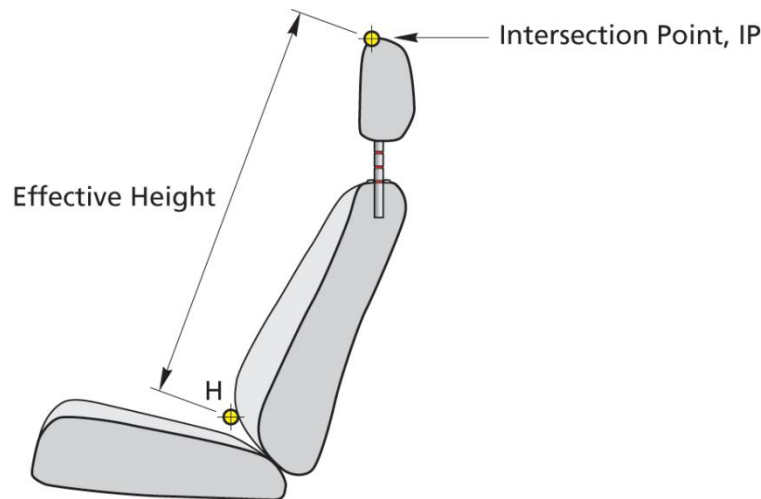

Figure 22: Effective Height.

Record the values as $(\text{Effective Height})_{\text{high}}$ and $(\text{Effective Height})_{\text{wc}}$.

2.5.7 Non-use position measurement

2.5.7.1 Automatic Return Head Restraints

Weight-based systems

- Set the head restraint in the non-use position.
- Position a 5th percentile female Hybrid III test dummy in the seat aligned with the CL/O and parallel to the XZ-plane.
- Hold the dummy's thighs down and push rearward on the upper torso to maximize the dummy's pelvic angle.
- Place the tibias as near to 90° to the thighs as possible. Push rearward on the dummy's knees to force the pelvis into the seat so there is no gap between the pelvis and the seat back or until the back of the dummy's calves touch the front of the seat cushion.
- Start the vehicle engine or turn on the master control switch. Record whether or not the head restraint moves to a use position.

2.5.7.2 Capacitance-based systems

- Set the head restraint in the non-use position.
- Turn on the ignition or start the vehicle engine.
- Sit a person of mass 75 ± 10 kg in the seat.
- Record whether or not the head restraint moves to a use position.
- Repeat the above steps in different types of clothing (light summer clothing; thick, padded winter clothing) to ensure repeatable operation of the automatic return system.

2.5.7.3 60° rotation evaluation

Set the head restraint in the lowest use locking position.

Position a digital inclinometer (which can measure to a precision of 0.1°) on a suitable surface of the head restraint. Record the angle measurement.

Fold or retract the head restraint forwards to the non-use position and record the angle again.

Subtract the folded/retracted angle from the angle recorded on the head restraint surface.

2.5.7.4 10° torso line change

Set the head restraint into the non-use position.

Install the HPM using the procedures in Section 2.5.2 and record the torso angle.

Subtract the torso angle measured in the line above from the torso angle of the HPM in Section 2.5.3 and record the value.

2.5.7.5 Discomfort metric

Set the head restraint into the non-use position.

On the surface given by the C/LO line, find the lowest point on the head restraint (TH) and record the related X-coordinate and Z-coordinate.

Calculate the X-coordinate recorded in the line above relative to the HPM X-coordinate, (ΔX).

$$\Delta X = X_0 - HPM X$$

Calculate the Z-coordinate recorded above relative to the HPM Z-coordinate, (ΔZ).

$$\Delta Z = Z_0 - HPM Z$$

Calculate H_{LE} (the height of the lowest point on the head restraint (T_H) relative to the HPM H-Point), using:

$$H_{LE} = \Delta X \cdot \sin(\text{Torso Angle}) + \Delta Z \cdot \cos(\text{Torso Angle})$$

Using the measuring device in APPENDIX E determine the thickness (S).

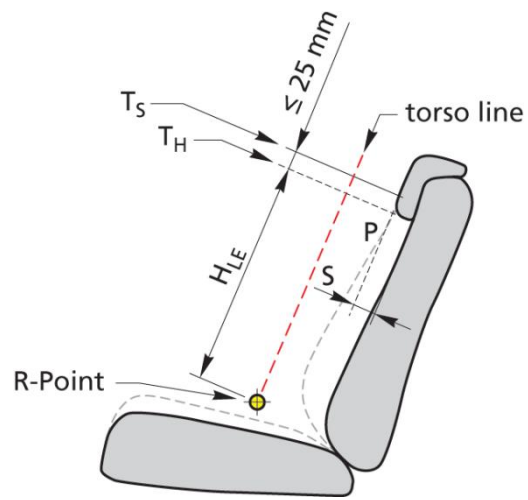

Figure 23: Discomfort Metric Geometric Requirements.

3 TEST PROCEDURE

3.1 Summary

Occupants	Assessment	Score	Total points	
Front	Geometry	Test position	-0.5 / + 0.5	
		Lowest and rearmost	0.5	
	Dynamic	High severity	1.5	
		Low severity	1.5	
Rear	Effective height	Highest position $\geq 770\text{mm}$	0.375	
		Lowest position $\geq 720\text{mm}$		
	$(\Delta\text{CP X})_{\text{mid}}$	$\leq (\Delta\text{CP X})_{\text{LIMIT}}$	0.25	1
	$(\Delta\text{CP X})_{\text{wc}}$	$\leq (\Delta\text{CP X})_{\text{LIMIT}}$	0.125	
	Non-use position		0.25	

* Points can be scored for backset only if the effective height requirements are met.

3.1.1 Front seat geometric assessment

The assessment is based on the worst performing parameter from either the height or backset.

Static measurements	HPL	LPL
Effective height	Test position	825mm
	Lowest and rearmost	-
Backset	Test position	45mm
	Lowest and rearmost	-

3.1.1.1 Lowest & rearmost

0.5/n points (where n = the number of front seats) will be available for each front seat scoring more than 0 points in the lowest and rearmost geometry assessment. For seats where the occupant must adjust the head restraint, the worst case geometry shall be measured in the lowest and rearmost position regardless of whether or not the seat is equipped with an active head restraint.

Alternatively, a means of ensuring that the head restraint is correctly positioned for different sized occupants without specific occupant action shall be offered. For these automatically adjusting head restraints, the lowest and rearmost geometry assessment shall be measured in the position as obtained in Section 2.1.7. This credit will only be available to seats performing well dynamically, with a raw score greater than 1.50 points after capping and all modifiers have been applied.

3.1.1.2 Seat structure assessment

Where the head restraint structure requirement is not met 0 points will be awarded for the overall geometric assessment.

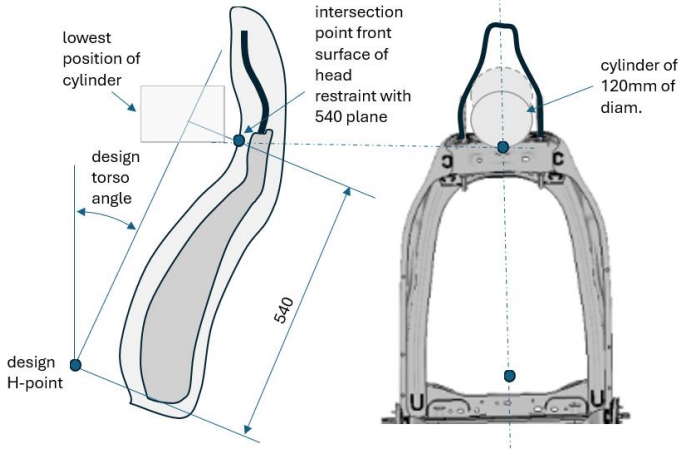
Head restraint structure assessment	
Seat back position	MDP
Head restraint position	Lowest
Procedure	<p>Integrated head restraints - Determine the intersection point of the plane which is 540mm distant from the design H-point perpendicular to the design torso line and the front surface of the head restraint which is situated in the vertical, longitudinal plane through the design H-point.</p> <p>Record coordinates of the intersection point and remove parts of less than 50 Shore A from the seat back and the head restraint.</p> <p>Place a cylinder of diameter 120mm $+1/-0$mm horizontally, but with its lowest edge not lower than the intersection point.</p> <p>The head restraint structure shall not allow the cylinder to pass from the front to the rear through the head restraint structure.</p>  <p>Non-integrated head restraints - Remove from the seat back and head restraint parts of less than 50 Shore A.</p> <p>Draw a horizontal tangent to the top the seat back (structure) in the vertical, longitudinal plane through the design H-point.</p> <p>Place a cylinder of diameter 120mm $+1/-0$mm horizontally, but with its lowest edge not lower than the horizontal tangent.</p> <p>The head restraint structure shall not allow the cylinder to pass from the front to the rear through the head restraint structure.</p>
Requirement	The head restraint structure shall not allow the cylinder to pass from the front to the rear through the head restraint structure.

3.1.2 Front seat dynamic assessment criteria and limits

Details of how the assessment criteria are calculated are provided in CP 005.

		NIC	+Fx	Fz	Total points
Front occupants	High severity	0.5	0.5	0.5	1.5
	Mid severity	0.5	0.5	0.5	1.5

Criterion			Mid severity			High severity		
			HPL	LPL	Capping	HPL	LPL	Capping
NIC		m ² /s ²	11.0	24.0	27.0	13.0	23.0	25.50
Nkm		-	-	-	0.69	-	-	0.78
Head rebound velocity		m/s	-	-	5.20	-	-	6.0
Upper neck	F _{X, shear} +ve	N	30	190	290	30	210	364
	F _{X, shear} -ve	N	-	-	360.0	-	-	360
	F _{Z, tension}	N	360	750	900	470	770	1024
	M _{Y, extension} MyOC	Nm	-	-	30.0	-	-	30.0
	M _{Y, flexion} MyOC	Nm	-	-	30.0	-	-	30.0
Lower neck	F _{X, shear} ABS	N	-	-	360	-	-	360
	M _{Y, extension}	Nm	-	-	30.0	-	-	30.0
	M _{Y, flexion}	Nm	-	-	30.0	-	-	30.0
T1 acceleration		g	-	-	15.55	-	-	17.80
T-HRC start	Time	ms	-	-	92.0	-	-	92.0
Seatback deflection		deg	-	-	-	-	-	32.0

3.1.3 Rear seat geometric assessment

Only outboard seating positions are assessed. Manufacturers will be asked to provide theoretical design data for R point position and torso angle of the two outboard seating positions. If these are the same to within the following tolerances the two outboard seating positions will be considered symmetrical and only one position needs to be measured:

R point position (vertical and horizontal): $\pm 2.5\text{mm}$

Torso angle: $\pm 0.5^\circ$,

Otherwise, the two outboard seating positions will be separately assessed. However, even in the case that manufacturer data indicates symmetry, the laboratory may assess the seating positions separately if they have reason to believe that the seats are not symmetrical.

3.1.3.1 Prerequisite

For a seating row to score points in the rear whiplash assessment, any centre seating position in that row needs to comply with the head restraint requirements of UN Regulation No. 17 in force at the time of vehicle homologation. This may be achieved by use of a separate head restraint or otherwise but, in any case, all vehicles in the model range must be equipped as standard with what is needed to ensure compliance.

Manufacturers will be asked for evidence (approval, technical service report) that the rear centre seat complies with the requirements of UN Regulation No. 17. For example, a vehicle with 3 seating rows having a restraint as standard in row 2 but not standard in row 3 can score points for row 2 only.

Cars which have no rear centre seating position (4 seaters for example) will automatically fulfil this prerequisite.

3.1.3.2 Effective height requirements

Effective height requirements	
The seating position shall be deemed to have met the height requirements of this protocol if <u>either</u> of the requirements of a) and b) below are met:	
a)	The effective height of the head restraint must meet the requirements of <u>both</u> the following: <ul style="list-style-type: none">- The effective height of the restraint is, in its lowest position, no less than 720mm- The effective height of the restraint is, in its highest position, no less than 770mm¹.
b)	If the interior surface of the vehicle roofline, including the headliner or backlight, physically prevents a head restraint located in the rear outboard designated seating position from attaining the height required by a) above, the gap between the head restraint and interior surface of the roofline, including the headliner or the backlight when measured as described below, shall not exceed 50mm when the head restraint is adjusted to its highest position intended for occupant use: <ul style="list-style-type: none">- If adjustable, adjust the head restraint to its maximum height and measure the clearance between the top of the head restraint or the seat back at all seat back angles for intended use and the interior surface of the roofline or the rear backlight, by attempting to pass a 50 ± 0.5mm sphere between them.

3.1.3.3 Backset requirements

Backset requirements	
Points can be scored for backset only if the effective height requirements are met.	
Using the torso angle, the calculated limit value of backset $(\Delta CP X)_{LIMIT}$ is determined using the following formula: $(\Delta CP X)_{LIMIT} = 7.128 \cdot \text{Torso angle} + 153$ This limit value is applied in both mid and worst case position.	

¹ Euro NCAP will monitor legislative requirements and may revise this figure in future years.

3.1.3.4 Non-use position assessment

Non-use position assessment	
<p>As a prerequisite for scoring for the non-use position, the height and backset assessment must score more than 0 points.</p> <p>If the head restraint is always in an in-use position and scores more than 0 points for geometry, the seating position scores 0.25 points. Seating positions with a non-use position compliant with one of the procedures described in 3.1.3.4 and which score more than 0 points for geometry also score 0.25 points. If no points are scored for geometry, no points can be scored for use/non-use positions.</p>	
a)	<p>Automatic return head restraints</p> <p>The head restraint needs to automatically go to the use-position from the non-use position at ignition on or when the engine is started.</p>
b)	<p>60° rotation evaluation</p> <p>The difference in head restraint angle needs to be larger than 60° between the in-use and non-use position. Rearward rotation or retraction of the head restraint to set the non-use position is not compliant with the requirements of this section.</p>
c)	<p>10° Torso line change</p> <p>The difference in torso angle between the in-use and non-use position needs to be larger than 10°.</p>
d)	<p>Discomfort metric</p> <p>The lower edge of the head restraint (H_{LE}) shall be not more than 460 mm, but not less than 250 mm from the R-Point and the thickness (S) shall not be less than 40 mm.</p>

3.1.4 Rear whiplash score

3.1.4.1 Raw score

Seat rows having a rear centre seating position meeting the prerequisites of 3.1.3.1 can score points for geometry and non-use position according to the following paragraphs.

The rear whiplash score for each seat is the sum of its geometry assessment score and its non-use position assessment score. The rear whiplash score is the sum of the scores for the two rear outboard seats (double the score for one seat in the case of symmetric seating positions).

For a vehicle with a third row the scores of the second and third row are added and scaled to a maximum of 1 point. Vehicles with no subsequent seating positions after the front row are excluded from the assessment.

3.1.4.2 Criteria and limit values

A maximum of one point is awarded for each seating position based on the Effective Height measurements, backset ($\Delta CP X$) and non-use position.

Where the height requirements are met 0.375 points are awarded. If the height requirements are met, additional points are awarded for the backset assessment if the backset requirement is met in the mid head restraint position ($\Delta CP X$)*mid. Where the ($\Delta CP X$)*mid points are awarded a further half point is awarded if the backset is met in the worst-case position ($\Delta CP X$)*wc; additional points can be scored if the requirements for non-use position are met.

4 POSTTEST ASSESSMENT & INSPECTION

4.1 Inspection

Euro NCAP will perform an inspection where modifiers can be applied. The inspection manual describes the inspection procedure and the criteria applied.

4.1.1 Dynamic modifiers

Test penalties	Modifiers	Criteria	Modifier score
Dummy loading	Exploiting dummy artefact	Inspection	-1

APPENDIX A HPM CALIBRATION PROCEDURE

1. Introduction

For the purposes of standardised seating positions for anthropomorphic test devices the SAE (Society of Automotive Engineers) designed the H-point manikin that allowed a uniform definition of the human H-point.

2. Scope

This procedure is designed to allow the calibration of HPM to restrict build tolerance variations of items currently poorly controlled and allow more repeatable and reproducible results.

3. HPM calibration jig

The HPM unit is held in a jig, known as GLORIA, which will facilitate calibration. The jig is equipped with feet at each corner to facilitate levelling. The jig holds the seat pan by three horizontal bars of 20mm thickness that support the seat pan allowing the thigh bar to be horizontal. The back pan is supported by 900mm vertical bar with its origin at the base of the seat pan in the area of the buttock. This vertical support has a horizontal bar at the level of the weight hanger bar and is level. A cord is attached to the back pan to prevent the HPM falling forward.



Figure 24: HPM Calibration Jig (GLORIA)

4. Set Up and Assembly of GLORIA Jig

- 4.1. The calibration should be carried out in a room with temperature at $20^{\circ} \pm 5^{\circ}$, HPM and GLORIA jig should have been soaked in that same environments for 6 hours.
- 4.2. The GLORIA jig should be set on a nominally level surface and levelled by adjustment of the threaded feet. The base plate should be levelled using an inclinometer. Surfaces to be used as reference are the lower horizontal section of the side rails and the seat pan support rods. Then the front and side surfaces of the vertical support should be checked to ensure the column is still vertical. All four measurements should be undertaken to ensure the unit is level. Tolerance for this levelling operation is $\pm 0.1^{\circ}$.
- 4.3. Remove the H-Point locator rods from the jig left and right.

- 4.4. Remove the Vertical H-Point to weight hanger bar supports along with the weight hanger guide assembly by extracting the removable rods.
- 4.5. Loosen the four bushes on the seat pan front and rear horizontal support bars and slide them outboard.
- 5. Preparation of HPM prior to Calibration**
 - 5.1. Remove the H-Point locator plugs from the seat pan left and right.
 - 5.2. When re-assembling the HPM manikin without the Head Room Probe care should be taken to ensure that the H-Point pivot nuts are tightened to a torque of X-Y Nm. When set at this torque the manikin back pan can fall forward hence the use of the support strap.
- 6. Installation and Calibration of HPM**
 - 6.1. Fold the HPM forward to allow easier installation into the jig.
 - 6.2. Install the HPM into the jig ensuring that the rear of the seat pan is in contact and square to the rear upper horizontal bar.
 - 6.3. Centre the seat pan on the horizontal support bars and slide the bushes inboard allowing them to contact the seat pan. Tighten the bushes' set screws.
 - 6.4. Adjust the rear Concentric Adjustment Bar from both sides to visually align the H-point holes forward and aft on the HPM seat pan with the corresponding holes on the side plates of the jig.
 - 6.5. Adjust the lower Concentric Adjustment Bar from both sides to visually align the H-point holes up and down on the HPM seat pan with the corresponding holes on the side plates of the jig.
 - 6.6. Install the H-Point locator rods through the vertical support guides and then into the H-point guides of the jig base and then through to the H-point holes on the HPM, see Figure 25.



Figure 25: H-Point locator bars installed through vertical support rods, jig side and HPM H-Point location.

- 6.7. Adjust the front Concentric Adjustment Bar from both sides to level the T-bar ($\pm 0.5^\circ$).
- 6.8. Check for horizontal play in the HPM at the H-Point / torso pivot to check for excessive wear. Tighten or replace as necessary.
- 6.9. Raise the back pan until it rests upon the jig's vertical support bar and secure with the elastic strap to prevent the back from tipping forward, see Figure 26.



Figure 26: HPM back pan held by retaining strap.

- 6.10. Install the weight hanger alignment fixture over the weight hangers to check for alignment. The fixture should be allowed to settle under its own weight, no force should be applied to fit. If this fixture will not locate then it indicates that the weight hanger bars are out of alignment and will require modification and the procedure should be terminated.
- 6.11. Remove the weight hanger alignment fixture and support strap. Tip the back pan forward and install the black cylindrical weight hanger bar guides at each out board end of the HPM weight hanger bars between the bars and the jig arms. Replace the back pan and support strap.
- 6.12. Visually check alignment of the weight hanger bar guides with the holes in the jig arms.
- 6.13. If alignment is correct then proceed. If it is not possible due to interference between the HPM back pan and vertical support then adjustment of the back pan to seat pan offset will be necessary which is outside the scope of this document. This procedure should therefore be terminated here.
- 6.14. If the alignment is not possible due to the misalignment of the HPM's weight hanger support rods then these should be adjusted to achieve alignment.
- 6.15. Raise the weight hanger guide bars either side of the jig and insert the weight hanger locator pins through the guide bars, arms and into the black cylindrical weight hanger bar guides, see Figure 27.



Figure 27: Weight hanger support pins inserted through weight hanger guide bars.

7. Calibration of the HPM

- 7.1. Once installed in the jig check to ensure that the flat portion of the HPM back pan is parallel to the vertical jig support and that the gap is no more than 4mm. It is allowed to touch, see Figure 28.



Zero to 4mm gap
between HPM back
pan and jig support

Figure 28: HPM installed into the jig. A check should be made to ensure that the gap between the HPM back pan and jig vertical support is no more than 4mm.

8. Attachment of Torso Angle Measuring Surface

- 8.1. Measure the trunk of the left hand weight hanger with a digital inclinometer, see Figure 29.



Figure 29: Measurement being taken of the torso angle at the weight hanger trunk by a digital inclinometer.

- 8.2. A calibrated Angle Measuring surface block should then be attached to ensure the left hand weight hanger trunk to ensure that an angle of $90^\circ \pm 0.3^\circ$ is indicated, see Figure 30.
- 8.3. If the angle of the left hand weight hanger is not at $90^\circ \pm 0.3^\circ$ then a calibrated and adjusted surface block should be installed in place of the standard item.
- 8.4. Check the angle of the installed calibrated surface block with a digital inclinometer to ensure that it shows a reading of $90^\circ \pm 0.3^\circ$.



Figure 30: Calibrated Torso angle measurement surface block attached to trunk of weight hanger arm.

APPENDIX B SLED PULSE SPECIFICATIONS

1. Definition

1.1. Offset Adjust the Accelerometer

In order to make sure that there is no initial acceleration, which result in a non-zero velocity profile, it is required to offset adjust the acceleration signal. It is assumed that this step is a standard procedure for the participating laboratories and shall therefore not be discussed into further detail.

1.2. Filter with CFC60

To ensure that low level noise does not influence the results the acceleration signal is filtered with a CFC 60 filter ('endpoints'-method in Diadem). The CFC 60 filter is used according to SAE J211, for sled acceleration signals.

1.3. Definition of T0

T0 is defined as the time before the CFC60 filtered sled acceleration reaches 1.0g. The times for the medium and high pulses are 5.8ms and 3.7ms respectively.

1.4. Definition of T1

T1 is defined as the time when the sled acceleration for the first time is > 1g. Both the initial onset of the pulse and specific low acceleration disturbances (< 0.5g) heavily influence the behaviour at the start of the pulse. For that reason, it is in practice not possible to identify the actual start of the pulse. Acceleration levels higher than 1g however are unmistakably a direct result of the pulse on the sled. As such, the moment in time when the sled acceleration crosses 1g can be uniquely and easily be found.

1.5. Definition of TEND

TEND is defined as the time when the sled acceleration for the first time is < 0g.

1.6. Definition of dT

dT is defined as the time span between TEND and T0,

$$dT = TEND - T0$$

1.7. Definition of dV

dV is defined as the difference between the maximum and minimum sled velocity between T0 and TEND, filtered at CFC180.

2. Medium Severity Sled Pulse Requirements

The sled acceleration must be within the corridors for the complete time interval from 0ms to 150ms as illustrated below. The corridor data points are detailed below.

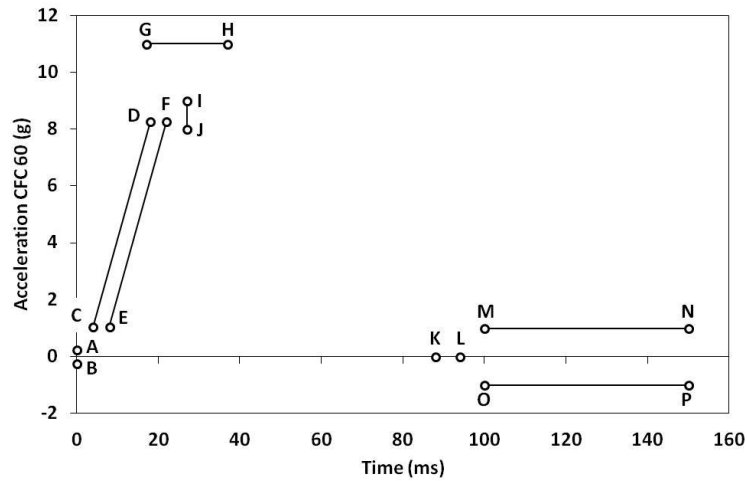

Parameter		Requirement	Limits +/-	Unit	
Velocity change	dV	15.65	0.80	km/h	
Mean acceleration	Amean	47.85	4.00	m/s ²	
	Time (ms)	Acceleration (g)		Time (ms)	Acceleration (g)
A	0	0.25	I	27	8.00
B	0	-0.25	J	27	9.00
C	4	1.0531	K	88	0.00
D	18	8.2705	L	94	0.00
E	8	1.0531	M	100	1.00
F	22	8.2705	N	150	1.00
G	17	11.00	O	100	-1.00
H	37	11.00	P	150	-1.00

Table 1: Medium pulse rise corridor

Time (ms)	Acceleration (g)	Time (ms)	Acceleration (g)
(C) 4	1.0531	(E) 8	1.0531
5	1.3751	9	1.3751
6	1.7443	10	1.7443
7	2.1608	11	2.1608
8	2.6230	12	2.6230
9	3.1276	13	3.1276
10	3.6691	14	3.6691
11	4.2406	15	4.2406
12	4.8336	16	4.8336
13	5.4384	17	5.4384
14	6.0446	18	6.0446
15	6.6414	19	6.6414
16	7.2181	20	7.2181
17	7.7645	21	7.7645
(D) 18	8.2705	(F) 22	8.2705

3. High Severity Sled Pulse Requirements

The sled acceleration must be within the corridors for the complete time interval from 0ms to 150ms as illustrated below.

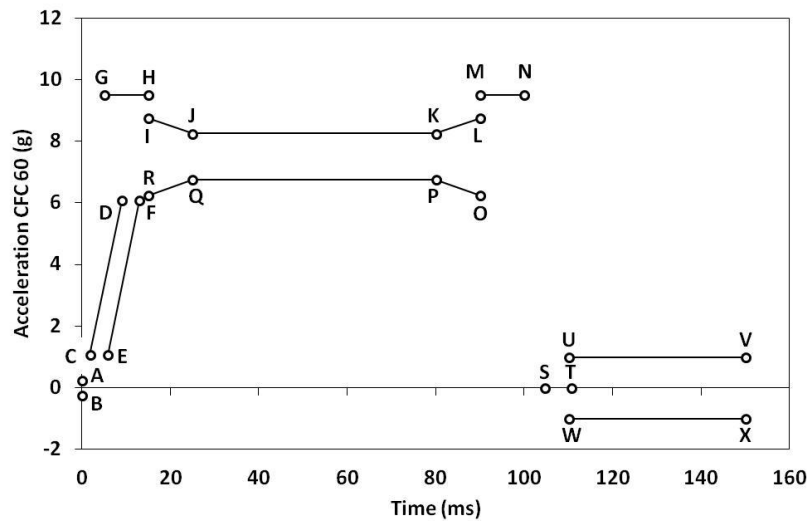

Parameter		Requirement	Limits +/-	Unit	
Velocity change	dV	24.45	1.2	km/h	
Mean acceleration	A _{mean}	63.15	4.85	m/s ²	
Maximum acceleration	A _{max}	7.50	0.75	g	
	Time (ms)	Acceleration (g)		Time (ms)	Acceleration (g)
A	0	0.25	M	90	9.50
B	0	-0.25	N	100	9.50
C	1.8	1.0714	O	90	6.25
D	9	6.0880	P	80	6.75
E	5.8	1.0714	Q	25	6.75
F	13	6.0880	R	15	6.25
G	5	9.50	S	104.7	0.00
H	15	9.50	T	110.7	0.00
I	15	8.75	U	110	1.00
J	25	8.25	V	150	1.00
K	80	8.25	W	110	-1.00
L	90	8.75	X	150	-1.00

The target rise of the low severity pulse has been calculated using the following formula:

$$\frac{A_{\max}}{2} \left\{ 1 - \cos \left(\frac{(t)\pi}{15.4} \right) \right\}$$

To establish the rise corridor C, D E & F, the portion of the target pulse from 3.8ms to 11.0ms is time shifted by -2.0ms for points C & D and +2.0ms for points E & F. This corridor should be calculated between time (t) = 3.7ms to 11.0ms.

APPENDIX C HEAD POSITION TABLE

Location of the back-of-head of two designated males in automotive posture with respect to the R50-point at several design torso angles, and their in-between "distance x"

Design torso angle	X-coordinate of back-of-head calculated for the mid-sized male	Z-coordinate of back-of-head calculated for the mid-sized male	X-coordinate of back-of-head calculated for the large male ²	"Distance between X-coordinates of back-of-head of both males"
	$504.5 \cdot \sin(\text{design torso angle} - 2.6) + 71$	$504.5 \cdot \cos(\text{design torso angle} - 2.6) + 203$	$593 \cdot \sin(\text{design torso angle} - 2.6) + 76$	$88.5 \cdot \sin(\text{design torso angle} - 2.6) + 5$
5	92	707	101	9
6	101	707	111	10
7	110	706	121	12
8	118	705	132	13
9	127	704	142	15
10	136	703	152	16
11	145	702	163	18
12	153	701	173	19
13	162	699	183	21
14	171	698	193	22
15	179	696	203	24
16	188	694	213	26
17	196	692	223	27
18	205	689	233	29
19	213	687	243	30
20	222	684	253	31
21	230	682	263	33
22	239	679	273	34
23	247	676	283	36
24	255	673	292	37
25	263	669	302	39
26	271	666	312	40
27	279	662	321	42
28	287	659	330	43
29	295	655	340	44
30	303	651	349	46

The large male is represented by a virtually up-scaled Torso and Neck Link; where the mid-sized male version of the Torso and Neck Link measures 504.5 mm and 203 mm with the head room probe 71 mm rearwards, the up-scaled version for the large male measures respectively 593 mm and 219 mm with the head room probe 76 mm rearwards

APPENDIX D HEAD RESTRAINT POSITIONS DEFINITIONS

The protocol refers to several head restraint positions – highest, lowest, mid, most rearward etc. This Annex defines how to establish these positions of the restraint.

1. Vertical adjustments

1.1. Highest use position

- 1.1.1. The highest position is considered to be the highest locking position. If a restraint has a non-locking position above the highest locking position, then the highest locking position is still considered as the highest position.

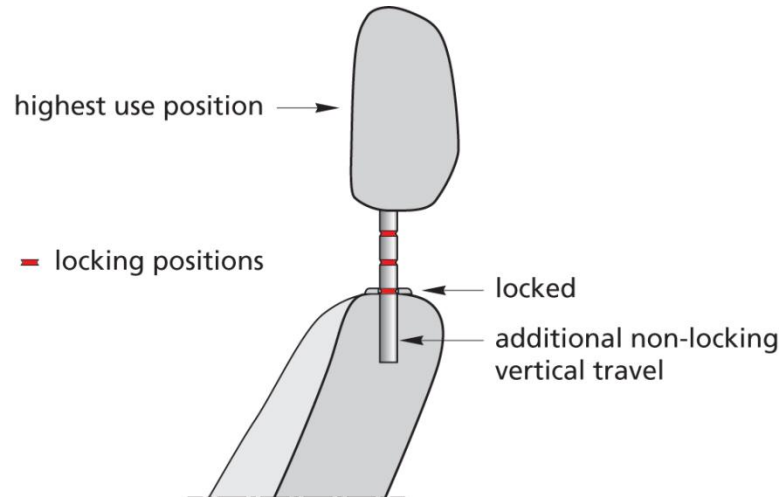

Figure 31: Highest Use Position.

1.2. Lowest use position

- 1.2.1. The lowest in-use position is considered to be the lowest locking or stowed position in which the restraint meets the minimum height requirements of Un regulation No. 17-08. See Figure 32 below.

1.3. Mid position

- 1.3.1. Mark a repeatable reference point on the top of the head restraint. This point is typically the highest point on the centreline of the head restraint.
- 1.3.2. Place the head restraint in the Lowest Use position as defined in 1.2.

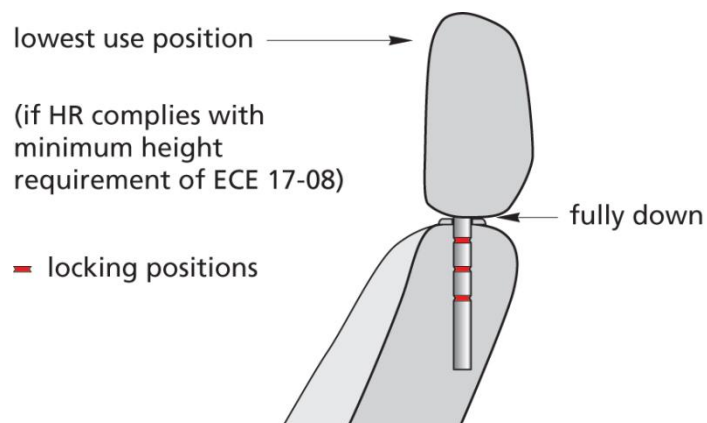

The fully down position complies with R17-08 height requirement and is therefore the Lowest Use position.

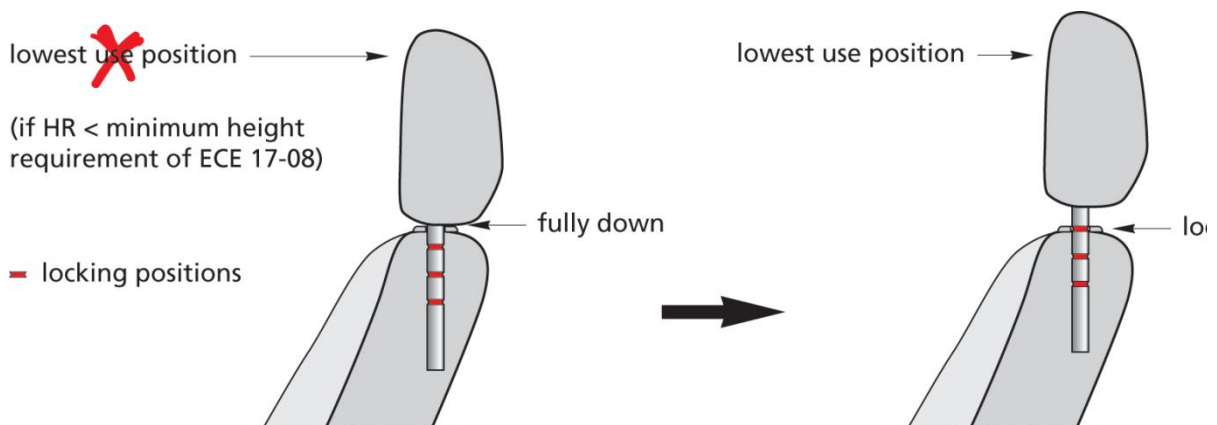

The fully down position does not comply with R17-08 height requirement. In this case, the lowest notch is Lowest Use position

Figure 32: Examples of setting Lowest Use position

- 1.3.3. Using a coordinate measurement device, measure the reference point in the Lowest Use position as defined in Section 1.3.2, and then in the Highest Use position without altering tilt or any other seat settings, see Section 1.1.
- 1.3.4. Midrange height position is determined by calculating the geometric mid point between the lowest position, and highest locking vertical adjustments, considering only the vertical component of measurement. The test position will then be selected based on the following conditions:
 - 1.3.5. Place the head restraint at the geometric mid point if a locking position exists there.
 - 1.3.6. If there is no locking position at the geometric mid point, raise the head restraint by up to 10mm. If a locking position exists within this 10mm of travel, that position will be the test position.
 - 1.3.7. If there is no locking position within 10mm above the geometric mid point, lower the head restraint to the next lowest locking position.
 - 1.3.8. If there is no locking position before the lowest or stowed position is reached, then the head restraint should be positioned fully down. This will only be the case if the head restraint complies with the height requirements of UN regulation No. 17-08 in the fully down position (i.e. fully down is the Lowest Use position)
- 1.3.9. Once the vertical test position has been determined, ensure the head restraint is returned to rearmost tilt position.

1.4. Examples of Single Notch Head Restraint

- 1.4.1. Lowest/Stowed Position meets UN regulation No. 17-08 height requirements
 - The Highest Use position is at the notch.
 - In the fully lowered/stowed position, the head restraint complies with the height requirements of UN regulation No. 17-08. Therefore, this is the Lowest Use position.
 - There is no notch at the geometric mid between Highest Use and Lowest Use positions.
 - The method of 1.1.3 is followed: if the notch is within 10mm upward of the geometric mid, the notch position becomes the Mid Position (as well as being

the Highest Use position); otherwise the Mid Position becomes the fully lowered/stowed position.

1.4.2. Lowest/Stowed Position does not meet UN regulation No. 17-08 height requirements

- The Highest Use position is at the notch.
- In the fully lowered/stowed position, the head restraint does not comply with the height requirements of UN regulation No. 17-08. The first locking position in which the head restraint complies with UN regulation No. 17-08 is at the notch. The notch position therefore becomes the Lowest Use position.
- The notch position is both the Highest Use and Lowest Use positions.
- The notch position also becomes the Mid Position

1.5. Tilt Adjustment

1.5.1. The following procedure should be used for locking horizontal adjustments only. For non-locking tilt adjustments, the head restraint should always be tilted fully rearward

1.5.2. Most rearward tilt position shall be that which results in greatest backset measurement of the Contact Point CP. In the situation where the head restraint cannot be placed at most rearward tilt (e.g. due to a return spring), the most “most rearward tilt” shall be the most rearward position in which the tilt can be locked.

1.5.3. Most forward tilt position shall be that which results in the smallest backset measurement of the Contact Point CP. It shall be determined by finding the most forward locking tilt position. Non-locking positions located further forward than the most forward lock are disregarded.

1.5.4. Midrange tilt position is determined by calculating the geometric mid point between the most rearward tilt and most forward locking horizontal adjustments, considering the backsets measured. Midrange tilt setting shall be undertaken using the same rationale as used in Section 1.3. A locking position shall be sought within a window 10mm forwards from the geometric mid point. If a lock is found within this window, that position shall be considered the test position. In the absence of a lock within this range the head restraint should be moved rearwards until the next locking position is reached. If no locking positions are reached before the fully rearward tilt position, then fully rearward tilt shall be the position used.

APPENDIX E DISCOMFORT METRIC MEASURING DEVICE

Example of a pass/fail gauge to be used with an inclinometer to examine if a shingled head restraint in the non-use position meets the thickness requirement (S), at a height of 25mm above the lowest point on the head restraint along the torso angle line.

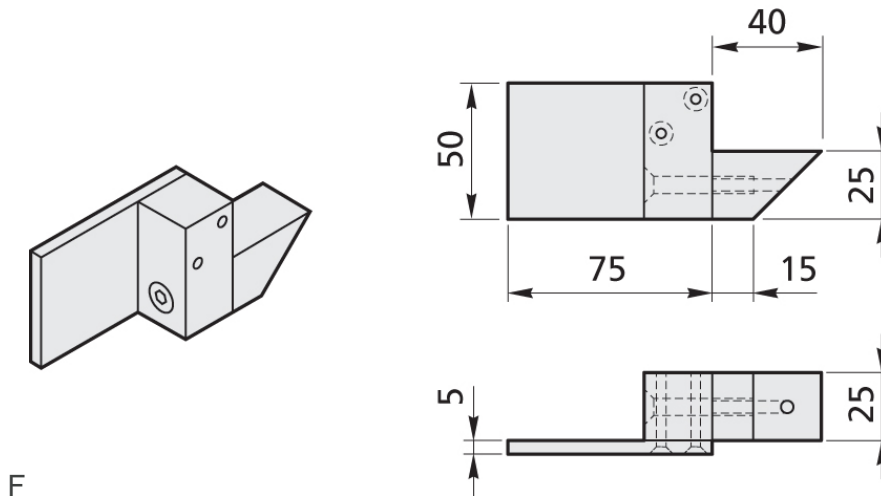

Figure 33: Discomfort Metric gauge design example (all dimension in mm).

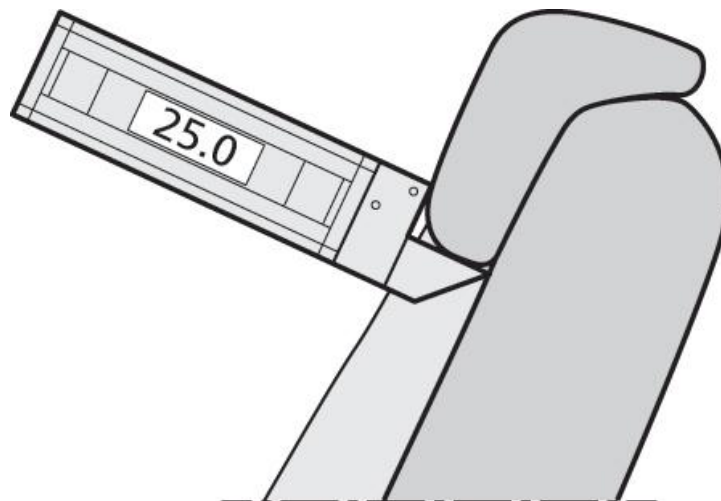

Figure 34: Using the gauge with an inclinometer