

Crash Protection

Side Impact

Protocol

Implementation January 2026

Copyright © Euro NCAP 2025 - This work is the intellectual property of Euro NCAP. Permission is granted for this material to be shared for non-commercial, educational purposes, provided that this copyright statement appears on the reproduced materials and notice is given that the copying is by permission of Euro NCAP. To disseminate otherwise or to republish requires written permission from Euro NCAP.

PREFACE

During the test preparation, vehicle manufacturers are encouraged to liaise with the laboratory and to check that they are satisfied with the way cars are set up for testing. Where a manufacturer feels that a particular item should be altered, they should ask the laboratory staff to make any necessary changes. Manufacturers are forbidden from making changes to any parameter that will influence the test, such as dummy positioning, vehicle setting, laboratory environment etc.

It is the responsibility of the test laboratory to ensure that any requested changes satisfy the requirements of Euro NCAP. Where a disagreement exists between the laboratory and manufacturer, the Euro NCAP secretariat should be informed immediately to pass final judgment. Where the laboratory staff suspect that a manufacturer has interfered with any of the setup, the manufacturer's representative should be warned that they are not allowed to do so themselves. They should also be informed that if another incident occurs, they will be asked to leave the test site.

Where there is a recurrence of the problem, the manufacturer's representative will be told to leave the test site and the Secretary General should be immediately informed. Any such incident may be reported by the Secretary General to the manufacturer and the person concerned may not be allowed to attend further Euro NCAP tests.

DISCLAIMER: Euro NCAP has taken all reasonable care to ensure that the information published in this protocol is accurate and reflects the technical decisions taken by the organisation. In the unlikely event that this protocol contains a typographical error or any other inaccuracy, Euro NCAP reserves the right to make corrections and determine the assessment and subsequent result of the affected requirement(s).

CONTENTS

SCORING	1
1 MEASURING EQUIPMENT	2
1.1 Reference system	2
1.2 Dummies	2
1.3 Collision partners	2
1.4 Measurement and variables	3
2 TEST CONDITIONS	4
2.1 VUT preparation	4
2.2 Occupant compartment adjustments	4
2.3 Adult dummy positioning	6
2.4 CRS installation and child dummy placement	8
2.5 Determining limited rear space for child occupants	11
3 TEST PROCEDURES	12
3.1 AE-MDB	12
3.2 Pole	13
3.3 Colour band scheme	14
3.4 Injury criteria and limits	15
3.5 Far side protection	17
4 POSTTEST ASSESSMENT & INSPECTION	25
4.1 After test	25
4.2 Inspection	32

SCORING

Crash Protection – Side Impact assessments	Total points 35
AE-MDB test	15
Driver - WorldSID 50 th	10
Rear passenger - Q10	2.5
Rear passenger - Q6	2.5
Pole test	10
Driver - WorldSID 50 th	10
Far side	10
Occupant to Occupant - Full scale pole test	2
Driver - Main loadcase - AE-MDB	2
Driver - Main loadcase - Pole	2
Driver - Robustness - AE-MDB	2
Driver - Robustness - Pole	2

Definitions used in this protocol can be found in Euro NCAP Technical Bulletin CP 001.

Any of the following post-test conditions identified in either the full-scale AE-MDB or Pole tests will disqualify the vehicle from any rewards in far side occupant protection.

- Structural failure of the door; its attachments to the body, the roof/cant rail and sill.
- Detachment of door latches, hinges, fully opened doors or structural failures of the roof/cant rail and sill.
- Failure of restraint system failures that are intended for far side occupant protection. For example, incorrect deployment of centre (occupant to occupant) airbags.
- Where the total score for the driver occupants in the AE-MDB and pole impacts is below 17.0 points out of 20.

1 MEASURING EQUIPMENT

Data processing and reporting shall be in accordance with Technical Bulletin CP 005. All film and photography requirements are detailed in the Euro NCAP Film and Photo protocol.

1.1 Reference system

The sign convention used for configuring the transducers is stated in SAE J211 (2022).

1.2 Dummies

All Anthropometric Test Devices (ATD) shall conform to the specifications detailed in the respective Technical Bulletins below:

Test	ATD
AE-MDB	WorldSID 50 th percentile - CP 202 Q6 and Q10 child - CP 009
Pole	WorldSID 50 th percentile - CP 202
Far side sled and VTC	WorldSID 50 th percentile - CP 202

1.3 Collision partners

1.3.1 Side impact MDB

The Mobile Deformable Barrier (MDB) used in the side impact includes both a barrier face and trolley. The trolley and Advanced European Mobile Deformable Barrier face (AE-MDB), including ventilation frame, shall conform to the specifications of Technical Bulletin CP 201.

1.3.2 Pole impact vehicle carrier and pole

The rigid pole is defined in UN Regulation No. 135, Annex 3, February 2016. It shall be set away from any mounting surface, such as a barrier, block or other structure, so that the vehicle will not contact such a mount or support at any time within 100ms of the initiation of the vehicle to pole contact.

A line must be marked along the vertical centreline of the pole which may be used to check the alignment of the test vehicle on the carrier.

A vehicle carrier must be used which has a horizontal flat surface with a sufficiently large area to allow unobstructed longitudinal displacement of the vehicle of about 1000mm and rotation of the vehicle during the deformation phase of the impact. To minimise effects of friction between the tyres of the test vehicle and the surface of the carrier this friction is reduced to a minimum by placing the vehicle with each tyre on two sheets of PTFE.

To avoid vehicle movement prior to the impact, the vehicle may be fixed to the carrier until 5m before the point of impact. The impact speed should be reached 10m before the point of impact.

Crumple tubes or a comparable device will decelerate the carrier not earlier than 80ms after the moment / point of impact. Where floor deceleration occurs before head to head contact or any peak injury criteria it must be shown that there has not been an influence on the dummy kinematics.

Euro NCAP

Version 1.0 — March 2025

The carrier may be fitted with an emergency abort system. This is optional; the test facility may elect to test without an abort system.

1.4 Measurement and variables

1.4.1 Instrumentation general

All instrumentation used in the test shall be (re-)calibrated within at least one year before each test and should be re-calibrated if it reaches its Channel Amplitude Class (CAC) during any test.

The measurement data shall be recorded according to ISO 6487 or SAE J211/1 (2022) at a minimum sample frequency of 20kHz. For sled and virtual testing, data shall be provided to Euro NCAP with a sample frequency of 10kHz.

1.4.2 VUT instrumentation

Location	Parameter	CAC
B-pillar - unstruck side	Acceleration, A_y	350g
Low voltage battery - including any secondary batteries	Supply voltage, V_{low}	60V
High voltage battery	Propulsion voltage, V_{high}	1000V

The B-pillar accelerometer is to be fitted to a tolerance of ± 1 degree and parallel to the Y-axis of the vehicle.

1.4.3 AE-MDB trolley instrumentation

Location	Parameter	CAC
Trolley C of G	Acceleration, A_x	150g

1.4.4 Pole test vehicle carrier instrumentation

Location	Parameter	CAC
Carrier C of G	Acceleration, A_x	350g

1.4.5 Far side sled instrumentation

Location	Parameter	CAC
B-pillar, non-struck side	Acceleration, A_x, A_y	150g
Sled	Acceleration, A_x	150g
Driver seatbelt shoulder and lap* sections	Force, $F_{diagonal}, F_{lap}$	16kN

* Care must be taken to position the lap belt transducer outboard of the dummy so that it does not interfere with the dummy/interior during the impact.

2 TEST CONDITIONS

2.1 VUT preparation

In advance of test preparation, the OEM shall provide Euro NCAP and the test laboratory with the information detailed in Technical Bulletin CP 002. Prepare the vehicle as defined in Technical Bulletin CP 004.

2.2 Occupant compartment adjustments

Position the seats as detailed below. Adjustments not listed shall be set to mid positions or the nearest position rearward, lowest or outboard. Adjustments are to be made following the order in each table.

Where specific settings are NOT indicated for either the driver or passenger, the same MDP and setting must be used for all occupants. For seat movement definitions, see CP 001.

2.2.1 50th percentile occupants

Adjustment	Required setting - WorldSID
Fore/aft	As per UN Regulation No. 135. Driver - Must not be further rearward than 95 th percentile position. Passenger – As driver. Pole impact passenger - seat in rearmost, the head CoG must be no further rearward than the impact line.
Front seat cushion tilt	As per UN Regulation No. 135.
Front seat height	As per UN Regulation No. 135.
Front seat torso angle	MDP otherwise 25° torso angle
Front seat lumbar support	As per UN Regulation No. 135.
Front seat cushion length	Fully retracted
Front head restraint	Fore/aft or tilt - Mid position. Height - Mid position.
Front seat belt anchorage	MDP or mid
Arm-rests	Adjustable arm-rests on the seat back will have them positioned in the 'not in use' position Adjustable arm rests as part of the centre console will have them positioned fully down and fully retracted. The lid of any arm rest/storage compartment shall be closed.

2.2.2 Rear seats

The rear seat settings must be the same for MPDB, FWDB and AE-MDB tests.

Adjustments	Required setting
Rear seat facing	Forwards
Rear seat lateral position	Most outboard
Rear seat fore/aft	Rearmost
Rear seat cushion tilt	MDP up to mid position, otherwise mid
Rear seat height	MDP up to mid position, otherwise lowest
Rear seat back angle	MDP, otherwise 25° torso angle
Rear seat lumbar support	Fully retracted
Rear seat cushion length	Fully retracted
Rear head restraint	Fore/aft or tilt - MDP, otherwise mid Height - Lowest in use Remove if the vehicle handbook allows for CRS use.
Rear seat belt anchorage	MDP per stature, otherwise mid
Arm-rests (rear seats)	Not in use position

2.2.3 Other settings

Other settings	Required setting
Steering wheel	Highest position and closest to driver
Side window glazing	Front & rear - All raised
Gear change lever	In the neutral position
Parking brake	Engaged. If the vehicle transmission automatically engages park when the parking brake is engaged, return the transmission to the neutral position. If the vehicle does not allow the transmission to be in neutral with the parking brake engaged, the transmission may remain in park. Where a powertrain or energy management prevents the restraint system firing when the parking brake is engaged, perform the test with the parking brake disengaged.
Pedals	Normal position of rest or fully forward for adjustable pedals
Doors	Closed, not locked. Rear child locks disengaged. See Post Crash protocol for ADL requirements.

Other settings	Required setting
Roof	Raised
Sunroof	Closed
Sun visors	Stowed
Rear view mirror	Normal position of use
Front passenger airbag	Pole O2O only – Vehicles equipped with automatic restraint system (e.g. airbag/pretensioner) disabling and default OFF may require specific actions enable the airbag.

2.3 Adult dummy positioning

It is the intention that the dummy is not left to sit directly on the seat for more than 2 hours prior to the test. It is acceptable for the dummy to be left in the vehicle for a longer period, provided that the dummy position is checked no more than one hour prior to test.

Measure the location of the H-point manikin 50th percentile using the procedure defined in Addendum 6 of M.R.1.

Once the WorldSID has been correctly positioned record the measurements defined in CP 202.

2.3.1 Dummy Placement

If, after dummy positioning, the vehicle is moved or a test run is aborted ensure that the dummy has not moved from the intended pretest position. If there are difficulties with positioning of any dummy, the H-point location shall be prioritised.

The seat settings shall not be adjusted for dummy positioning with the exception of the fore/aft travel to establish the knee gap where required. If the dummy cannot be positioned within the specified tolerances after three attempts, then it is to be placed as close to the tolerance limits as possible. Record all settings detailed in the table below and those which were not within tolerance.

2.3.2 WorldSID positioning

Dummy part	Required setting
H-point	Within a square of $\pm 10\text{mm}$ in X and Z of a point 20mm forward of that of the manikin H-point. The X position shall be prioritised over the Z position.
Torso angle	Thorax tilt sensor should coincide with the angle specified by the manufacturer or -2° (spine flexion) $\pm 1^\circ$ when the torso angle is $25^\circ \pm 1^\circ$. Otherwise no further adjustment of rib angle is required. Dummy's back in contact with the seat back and the dummy centreline aligned with that of the seatback.
Head	Adjust the neck bracket to level the head at the closest position to $0^\circ \pm 1^\circ$. No other seat adjustments shall be made to achieve this.
Arms	At the first detent downward of the most upward detent corresponding to a differential angle of 32° between rib angle sensor and the arm angle.

Dummy part	Required setting
Legs	<p>Driver - Place the right foot on the undepressed accelerator pedal, with the heel as far forwards as allowable. Place left foot flat on the footwell at an equal distance from the seat centreline.</p> <p>Where a lack of ankle articulation prevents the foot from sitting flat on the accelerator pedal/floor, keep the foot at a 90 degree angle to the tibia and ensure that the heel is as far forward as possible and in contact with the floor.</p> <ul style="list-style-type: none"> - No distance is specified for the knee spacing. However, priority should be given to ensure the following: - There is 5 mm clearance between the knees/legs and the steering shroud, instrument panel and centre console. - There is a stable foot and ankle position. <p>The legs are as parallel as possible to the sagittal plane.</p> <p>Passenger - The feet shall be placed with the heel as far forwards as possible with the feet as flat on the floor as possible. Both legs and feet shall be as parallel as possible to the sagittal plane.</p>

2.3.3 Seat belt – all dummies

Adjust the seatbelt D-loop for the relevant occupant as detailed in the tables above, carefully place the seat belt across the dummy and lock as normal. It will be necessary to re-position the arm as described above.

Remove the slack from the lap section of the webbing until it is resting gently around the pelvis of the dummy. Only minimal force shall be applied to the webbing when removing the slack. The route of the lap belt should be as natural as possible.

Place one finger behind the diagonal section of the webbing at the height of the dummy sternum. Pull the webbing away from the chest horizontally forward and allow it to retract in the direction of the D-loop using only the force provided by the retractor mechanism. Repeat this step three times, only.

After following the above steps, the seatbelt should lie in a natural position across the dummy sternum assembly and shoulder clavicle. Where this is not the case, and the D-loop is adjustable, the anchorage shall be adjusted and steps above repeated.

The upper anchorage should be adjusted by a sufficient amount to ensure a natural belt position, this may require multiple attempts. For example, where the belt touches the neck the upper anchorage shall be lowered. Where the belt position requires adjustment, pictures must be taken showing the pre and post adjustment position.

Once the belt is positioned the location of the belt should be marked across the dummy chest to ensure that no further adjustments are made. Mark also the belt at the level of the D-loop to be sure that the initial tension is maintained during test preparation.

2.4 CRS installation and child dummy placement

The use of additional belt guides, clips or other components that are not an integral part of the CRS is prohibited. Belt guides that are fitted to the vehicle must be permanently attached and information on their use must be contained in the vehicle handbook, where this is not the case they MUST NOT be used for testing.

2.4.1 Q10 dummy installation

Attach a foam pad of 125mm x 90mm with a thickness of 20mm \pm 2mm to the rear of the dummy pelvis, outside the suit, using tape to hold it in place. The pad shall be centred on the midsagittal plane with the upper edge at the same height as the top of the pelvis flesh. This pad shall remain on the dummy for the test unless it can be removed without the need to move the dummy. The foam pad shall have the following properties:

Density of 152-200kg/m³

Compression deflection 25% of 89-118kPa

Dummy part	Required setting
Booster cushion	Place the booster cushion on the relevant seating position and mark the fore/aft position on the side of the CRS and vehicle. Align the CRS with the vehicle seat centreline and check that there is no interaction between the CRS and side door when it is closed. If there is interaction, the CRS may be moved inboard by up to 50mm. If an ISOFIX CRS is used no markings are needed, the CRS shall be aligned with the anchorages and engaged with the vehicle.
Q10 placement	<p>Place the dummy on the CRS with both aligned to the seat centreline. Ensure that the suit has not moved in the gap between femur and hip by pulling the suit towards the knees.</p> <p>Buckle the seatbelt. If the buckle is not accessible because of interaction with the CRS, move the CRS and dummy outboards a little as possible (max 50mm) to get free access to the buckle. Remove the slack from the webbing but do not tighten the webbing.</p> <p>Realign the CRS with the marks on the vehicle seat. If the CRS cannot easily be aligned with the original marks due to the shape of the vehicle seat or position of the seat belt buckle, then re-mark the new lateral position of CRS relative to vehicle seat.</p> <p>Ensure that the rear of the CRS is in contact with the seat back by pressing the CRS backwards against the seat and making sure that the fore/aft markings are still aligned.</p> <p>Where applicable, place the hip shields on the Q10 dummy. Ensure that the distance between the hip shields is no less than 154mm. If needed, a larger gap should be used to establish the best fit.</p>
Torso	<p>Ensure that the dummy's lower back is in contact with the vehicle seat back by bending the dummy's back into an upright position and then rocking the dummy sideways while at the same time pushing the pelvis backwards.</p> <p>Ensure that the booster cushion is aligned with the new reference marks and that the dummy is on the centreline of the CRS and not rotated about the vertical axis.</p> <p>Push the dummy's shoulders toward the seat back until either the shoulders contact the seat back or the head is in contact with the head restraint.</p>

Dummy part	Required setting
	<p>Ensure that the dummy is sitting in an upright position and is aligned with the centreline marks on the head restraint (if applicable) or is parallel to the marks of the centreline.</p> <p>Ensure that the CRS position did not change relative to the marked position</p>
Head	<p>If the head is pushed forwards by the head restraint, firstly move the head restraint rearwards in X, then in Z if required. If there is still interference and no further adjustment of the head restraint is possible continue with the test.</p>
Arms	<p>The upper arm shall be positioned parallel to the chest. The measurements shall be taken on the neoprene suit along the front surface of the arm (bicep) and between the two IR-TRACCs on the chest.</p> <p>Position the lower arms parallel to the upper legs resting on the booster cushion or armrest as close as possible to the side of the femur. The elbows shall be kept as close as possible to the torso. Where possible, the tip of fingers should be in line with the screws of the knee joint in the x-direction.</p>
Legs	<p>Position the femurs straight forward with a distance of 130mm \pm5mm between the centres of the knees. If the CRS prevents this gap from being achieved, position the knees as close to the target values as possible.</p> <p>Where possible, allow the lower legs to rest naturally. The tibias shall be parallel to the vehicle centreline and the feet shall be separated by the same distance as the knees.</p>
Seatbelt	<p>Follow the CRS installation instructions when routing the seat belt and ensure that the belt is routed correctly through any necessary belt guides.</p> <p>Remove the slack of the lap belt by pulling on the diagonal belt near the buckle with a force of 150N. Ensure that the belt is not twisted in the guidance of the booster cushion.</p> <p>The belt shall initially be positioned over the IR-TRACC (upper for Q10) if possible, a load of 50N shall be applied to the diagonal section of the belt in towards the D-loop to achieve a natural and flat position across the chest. The belt may have moved away from the initial position, there is no need for further adjustment.</p> <p>The use of any non-permanent belt guides or clips on either the vehicle or CRS is prohibited.</p> <p>There must be no tape or stickers applied to the diagonal section of the adult belt.</p>

Once the Q10 dummy has been correctly positioned, the two IR-TRACC holes shall be clearly marked on the suit of the dummy. Measure the Q10 dummy position as detailed in CP 009.

See Section 2.5 for details on establishing if the vehicle qualifies as limited rear space.

2.4.2 Q6 dummy installation

Dummy part	Required setting
Booster seat	Follow the procedure for Q10 detailed above.
Q6 placement	Follow the procedure for Q10 detailed above. Where the rear head restraints interfere with the CRS, they should be repositioned as necessary to avoid this. They may only be removed if instructed to do so in the vehicle handbook.
Torso	Ensure that the dummy's upper back is in contact with the vehicle seat back if seated on a booster cushion or the back of the CRS if seated in a booster seat. This is done by bending the dummy's back into an upright position and then rocking the dummy sideways while at the same time pushing the pelvis backwards. Ensure that the CRS is aligned with the new reference marks and that the dummy is on the centreline of the CRS and not rotated about the vertical axis. Push the dummy's shoulders toward the seat back or CRS until either the shoulders contact the seat back or the booster seat back. Ensure that the dummy is sitting in an upright position and is aligned with the centreline marks on the head restraint (if applicable) or is parallel to the marks of the centreline. Ensure that the CRS position did not change relative to the marked position.
Arms	The upper arm shall be positioned parallel to the chest. The measurements shall be taken on the neoprene suit along the front surface of the arm (bicep) and along the IR-TRACC on the chest. Position the lower arms parallel to the upper legs resting on the booster or armrest as close as possible to the side of the femur. The elbows shall be kept as close as possible to the torso.
Legs	Position the femurs straight forward with a distance of 150mm \pm 5mm between the centres of the knees. If the CRS prevents this gap from being achieved, position the knees as close to the target values as possible. Where possible, allow the lower legs to rest naturally. The tibias shall be parallel to the vehicle centreline and the feet shall be separated by the same distance as the knees.
Seatbelt	Ensure that the lap belt is routed through the belt guidance of the booster seat. Remove the slack of the lap belt by pulling on the diagonal belt near the buckle with a force of 150N. Route the diagonal belt through the belt guidance of the booster for boosters with high back. Ensure that the belt is not twisted in the guidance of the booster. The belt shall lie naturally across the chest and be allowed to sit as it falls. A load of 50N shall be applied to the diagonal section of the belt towards the D-loop to achieve a natural and flat belt position across the chest. The use of any non-permanent belt guides or clips on either the vehicle or CRS is prohibited. There shall be no tape or stickers applied to the diagonal section of the adult belt.

No dummy positioning measurements are taken for the Q6.

2.5 Determining limited rear space for child occupants

In advance of test preparation, the OEM shall inform Euro NCAP and the test laboratory if they anticipate the vehicle qualifying for limited rear space assessment by completing CP 002. Where a vehicle is deemed as limited rear space, by following the procedure below, the assessment shall be conducted as detailed in CP 008-1.

Reposition the front seat track 30mm forward of its test position. If there is no notch at this position, set the seat in the nearest notch forwards of 30mm. During repositioning, check for interaction between the Q dummy lower legs, feet and the front seat.

If there is no contact between the front of the dummy toes and the front seat when it is 30mm forward, reposition the front seats in their test positions. Interaction between the Q dummy lower legs, feet and the front seat is acceptable in this case. It is also acceptable for the top of the foot/toes to contact the underside of the front seat when it is 30mm forward. Record the pelvic angle.

If there is contact between the dummy and the front seats when they are 30mm forward of their test position, follow the steps below to limit contact between dummy and front seat. This is not relevant if there is only contact between the top of the foot/toes and the underside of the front seat.

Try to reposition the feet and tibias by pushing them beneath the front seat or rotating the tibias about the Z axis. If this is not sufficient then move the pelvis of the dummy forwards while keeping the CRS in place until there is no contact with the seat in front. It is permitted to change the pelvic angle up to 5 degrees relative to the initial pelvic angle. This should be done in incremental steps until the contact between the toes and front seat is removed. It is acceptable for the top of the foot/toes to contact the underside of the front seat. Record the final pelvic angle.

When the dummy toes remain in contact with the front seat after repositioning the dummy as mentioned above, the vehicle will be treated as limited rear space for that particular test. It is acceptable for the top of the foot to contact the underside of the front seat.

The front seat must be returned to the test position.

3 TEST PROCEDURES

3.1 AE-MDB

Front Occupant	Head	Chest	Abdomen	Pelvis	Total points
Driver	2.50	2.50	2.50	2.50	10

Rear Occupants	Head	Neck	Chest	Total points
Q6 (behind front passenger)	1.25	0.625	0.625	2.5
Q10 (behind driver)	1.25	0.625	0.625	2.5

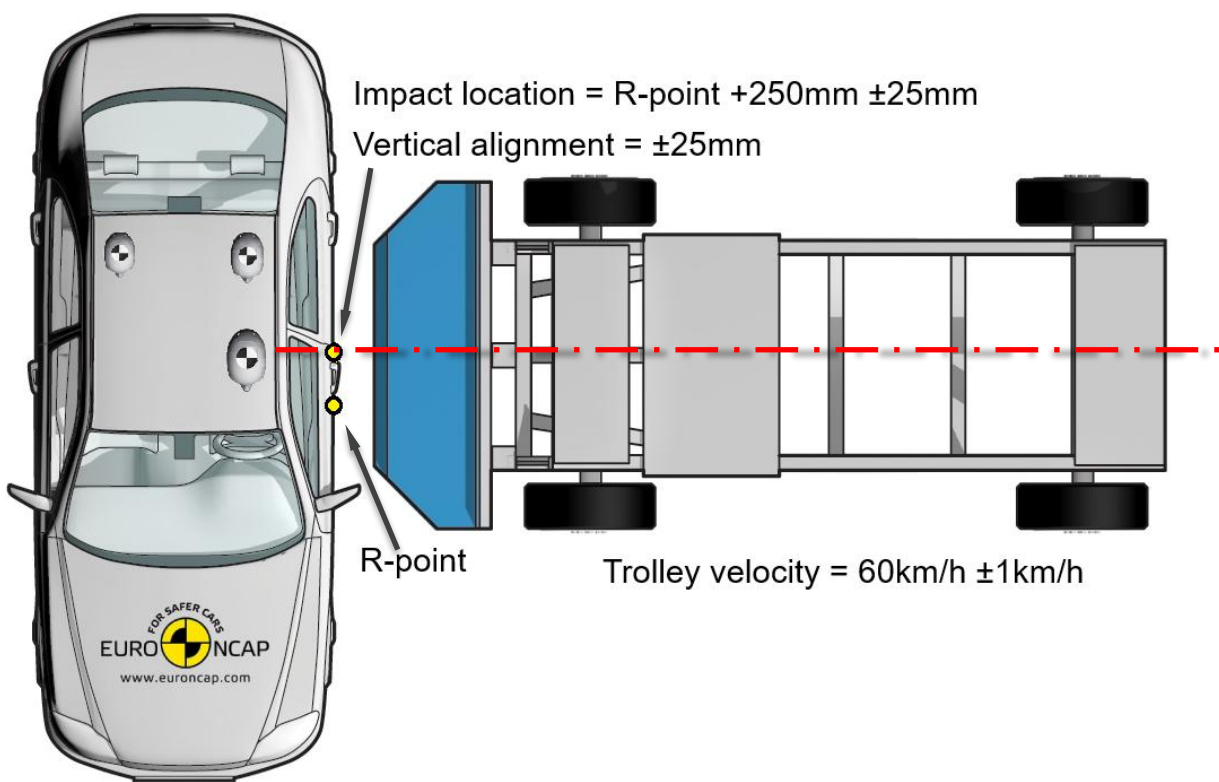

Figure 1: AE-MDB test

The laboratory shall include on the vehicle or AE-MDB face a physical means of identifying the impact alignment between the barrier face and vehicle at T0.

3.2 Pole

Front Occupant	Head	Chest	Abdomen	Pelvis	Total points
Driver	2.50	2.50	2.50	2.50	10
Occupant to occupant interaction*	2.00				See Section 3.5

*The occupant to occupant interaction score is part of the far side assessment

Where no near side head protection system(s) is present, the pole test will not be performed and the points for that test set to zero.

Where no far side countermeasure is present, the pole test will be performed with a driver only.

If the OEM can demonstrate that the presence of the passenger in the dual occupancy pole test will influence the nearside results of the driver, the OEM may sponsor (when agreed by Euro NCAP) an additional single occupant pole test to rate the near side pole impact performance.

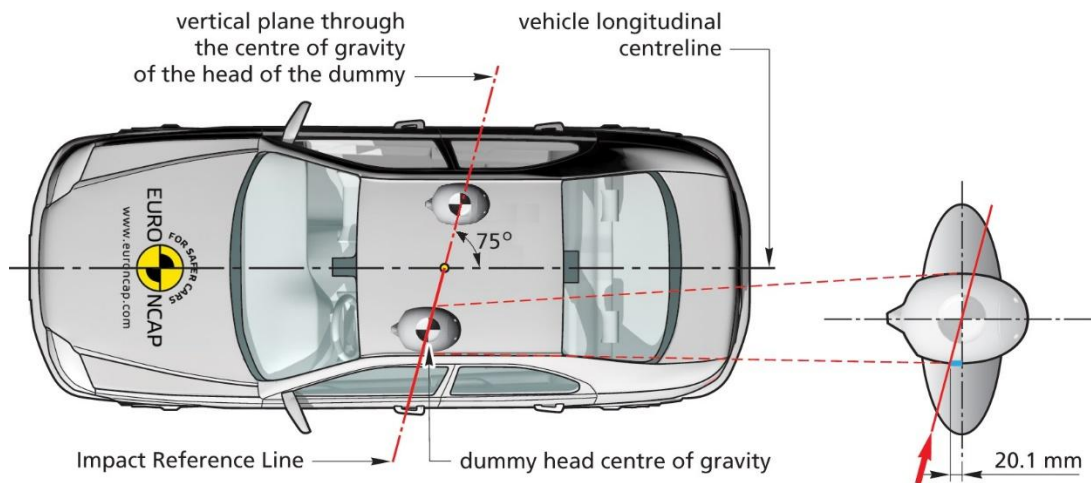

Figure 2: Pole impact reference line (IRL)

Impact location = IRL ± 25 mm
 VUT impact angle = $75^\circ \pm 3^\circ$

Carrier velocity = 32km/h ± 0.5 km/h

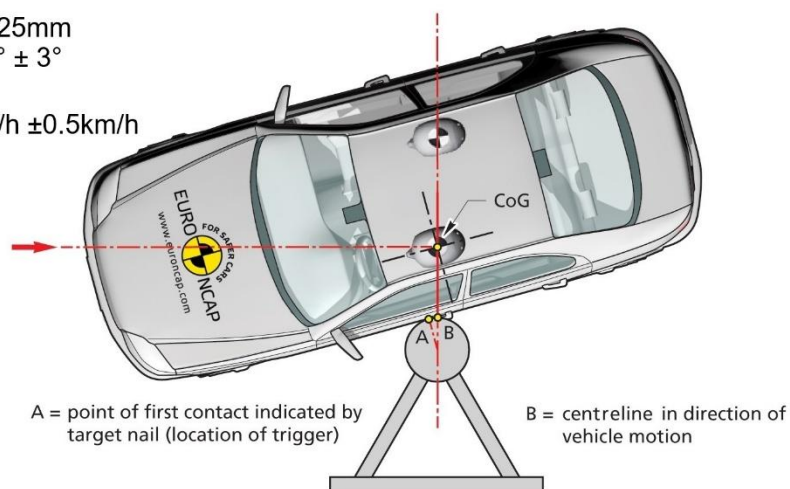

Figure 3: Pole impact location

During the acceleration phase of the test, the acceleration of the carrier shall not exceed 1.5m/s². The laboratory shall include on the vehicle or pole a physical means of identifying the impact alignment between the pole and vehicle at T0.

3.3 Colour band scheme

WorldSID	Criterion	Green	Yellow	Orange	Brown	Red
Body region	Limit value points	< HPL 100%	80%	40%	20%	≥ LPL 0%
Head	HIC ₁₅ -					
	A _{res-3ms} g					
Chest	D _{chest compression} mm					
Abdomen	D _{abdomen compression} mm					
Pelvis	F _{pubic symphysis} kN					

Q dummy	Criterion	Green	Yellow	Orange	Brown	Red
Body region	Limit value points	< HPL 100%	80%	40%	20%	≥ LPL 0%
Head	HIC ₁₅ -					
	A _{res-3ms} g					
Neck	F _{Z,tension} kN					
Chest	A _{res-3ms} g					

3.3.1 Prediction by OEM

The vehicle manufacturer may provide the Euro NCAP Secretariat with colour predictions detailing the protection offered by the vehicle based on CAE or in-house test data, which may then be used in the vehicle rating. Predictions must be provided to the Euro NCAP Secretariat before any test preparation begins. In order for ANY predicted data to be used in the rating, all of the following requirements must be met:

Prediction is provided for ALL full-scale tests – MPDB, FWDB, AE-MDB, Pole.

Prediction is provided for all dummies and applicable dummy assessment criteria detailed in Section 3.3 & 3.4.

Prediction is provided based on dummy performance without modifiers applied.

The predicted level of protection offered by the vehicle is verified by Euro NCAP with the use of the full scale tests. The difference between the predicted data and that recorded in the official test must be within 25% of the colour band width for each assessment criterion (LPL-HPL)/3.

When a measured dummy parameter performs better or worse than predicted, but within the tolerance, the predicted result is used in the rating. When a measured dummy parameter performs better or worse than predicted and is outside the tolerance, the measured value shall be used in the rating. After the results comparison has been made, any modifiers identified will then be applied to the relevant body regions and test scores.

An example of the prediction and scoring method is detailed in Technical Bulletin CP 006.

Where the OEM provides no predicted data or the data provided does not meet the requirements detailed above in this section, the vehicle rating shall be based on the measured results obtained in the official tests for ALL areas of the assessment.

3.4 Injury criteria and limits

Where multiple criteria exist for an individual body region, the lowest scoring parameter is used to determine the performance of that region.

3.4.1 Head & neck

Criterion		WorldSID 50 th	
		HPL - LPL	Capping
HIC ₁₅	-	500 - 700	700
A _{res-3ms}	g	72 - 80	80
A _{res}			
- Direct contact with pole	g	-	80
- O2O Head contact			

3.4.2 Chest

Criterion		WorldSID 50 th	
		HPL - LPL	Capping
D _{chest compression}	mm	28 - 50	50 - AE-MDB 55 - Pole

3.4.3 Abdomen

Criterion		WorldSID 50 th	
		HPL - LPL	Capping
D _{abdomen compression}	mm	47 - 65	65

3.4.4 Pelvis

Criterion	WorldSID 50 th		
		HPL - LPL	Capping
F _{pubic symphysis}	kN	1.7 - 2.8	2.8

3.4.5 Child occupants

Body region	Criteria		Q6 HPL - LPL	Q10 HPL - LPL	Capping
Head	HIC ₁₅	-	500 - 700	500 - 700	700
	A _{res-3ms}	g	60 - 80	60 - 80	80
Neck	F _{Z,tension}	kN	2.4	2.2	-
Chest	A _{res-3ms}	g	67	67	-

Injury parameter assessments will not be evaluated during the rebound phase of the dummy.

If no hard contact between the head and vehicle is observed on the high speed film, the head assessment is based on the Resultant 3ms acceleration only.

Chest acceleration peaks caused by the firing of seatbelt pretensioners early in the loading event will be ignored.

3.5 Far side protection

Loadcase			Head Excursion	Total points
Far side	Main loadcases	AE-MDB	2.0	4
		Pole	2.0	
	Robustness	AE-MDB	2.0	4
		Pole	2.0	

Front Occupant	Head	Total points
Occupant to occupant interaction*	2.00	2

*tested in the full scale pole test

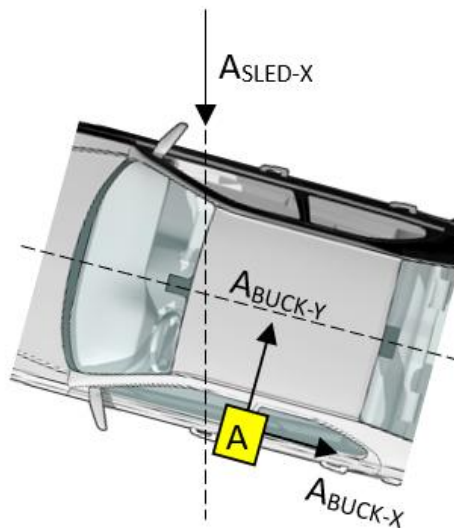

Figure 4: Far side impact

Far side protection will be assessed based on the virtual test data provided by the OEM for both the main and robustness loadcases. When the virtual test data is not provided or does not meet the VTC validation criteria and Technical Bulletins CP 500 & 520, only the main loadcases can be scored based on physical sled test data provided by the OEM.

3.5.1 Far side sled pulse

Pulse	Impact angle	Scaled sled pulse
AE-MDB	75°	$A_{X,SLED} = A_{Y,VEHICLE(AE-MDB)} \times 1.035$
Pole	75°	$A_{X,SLED} = A_{Y,VEHICLE(POLE)} \times 1.035$

The suitability of the correlation between the vehicle and sled pulses will be checked according to the method detailed in Technical Bulletin CP 500.

3.5.2 Active restraints

Active restraint systems shall be standard equipment and identical to those used in the Euro NCAP full scale tests and shall be consistent between simulations and tests and shall be used for all loadcases.

Pretensioners must be triggered if the firing strategy is such that they are triggered in the side and pole impact tests. Triggering of pretensioners will be accepted on the sled if the difference in deployment time from the official tests is no greater than +/-2ms. Where the difference is greater than 2ms, data must be supplied showing that this did not affect the result. Where there is a different firing strategy between near side and far side occupants, the OEM will have to provide justification in the far side dossier.

Triggering of other active restraints, such as the side curtain and seat mounted airbags, will not be permitted unless it can be shown that these systems have been designed as a countermeasure intended to lower the risk of far side occupant injury. For example, a head curtain airbag that extends beneath the door level, or a seat mounted airbag that can remain sufficiently inflated for the required length of time to limit occupant excursion.

3.5.3 Virtual test data

The far side simulation data for both main and robustness loadcases must be supplied in advance of the physical validation far side sled testing.

3.5.4 Validation tests

Two physical validation sled tests are required for the validation of the provided simulation data. Euro NCAP will randomly select a main loadcase and a robustness loadcase for validation. It will be ensured that one of the loadcases is an AE-MDB loadcase and the other one a Pole loadcase.

When the simulation data has been approved, a unique far side test reference number will be provided to the vehicle manufacturer by Euro NCAP. This number must be placed physically on the sled/BIW and visible in all videos, photos and referenced in the .mme file.

3.5.4.1 Excursion line marking

A chequered or similar grid measuring 50x50mm shall be rigidly mounted to the BIW directly behind, but not attached to the front seats in a way that does not result in interference during the test.

Four vertical and parallel excursion lines will be marked in the BIW for both sled test scenarios. The most inboard edge of each line shall be used as the excursion limit. All markings must be extended onto the chequered grid board positioned behind the front seats, the vehicle roof beam and fascia.

Excursion line	Description
Red - Maximum intrusion	This line is marking the maximum post-test intruding point of the interior door panel from AE-MDB (60km/h) and 75° pole impacts respectively. The method to determine the maximum deformation is detailed in CP 004. Peak intrusion values will be compared to those observed in the official tests. The OEM shall provide details of the measurement point used for establishing the intrusion lines. Where the red line is further inboard than any of the other excursion lines, those lines will not be marked on the BIW.
Orange – Excursion limit	Struck side seat centreline, pre-test, without intrusion.
Yellow – Excursion limit	125mm inboard of the struck side seat centreline.
Green – Occupant interaction limit	250mm inboard from the struck side seat centreline
Blue – Vehicle centreline	Y=0

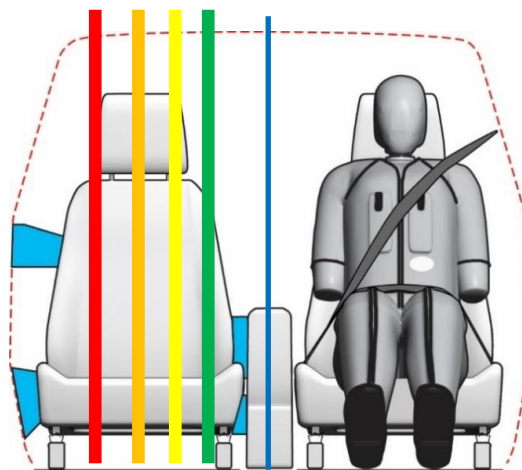

Figure 5: Excursion lines to be attached to sled

3.5.4.2 Test setup

The far side test set up should be of the same specification as the full scale AE-MDB and Pole tests. This includes, but is not limited to, the transmission, front seats, restraints and interior trim/centre console. The seats of the bestselling variant (as per AE-MDB and pole impacts) will be used in the 'body in white' BIW. In house test vehicle variants may differ slightly from the

official model tested by Euro NCAP e.g. engine etc. This is so that testing can be performed in advance of the official Euro NCAP tests. All features which may influence occupant kinematics and protection must be installed in the BIW.

The BIW may be either a right or left-hand drive vehicle and shall be mounted with the centreline at $75^\circ \pm 3^\circ$ towards the direction of travel. A BIW that is of a pre-production state will be accepted if it is shown to be representative of series production and that any differences have no influence on the far side assessment.

The bodyshell shall be mounted on the sled such that there will be no permanent deformation of the body or its mounts during the tests. Struck side intrusion will not be replicated on the BIW and neither driver nor passenger doors are required.

Structures that are forward of the A-pillar and windscreen cowl and rearward of the B-pillar may be removed from the BIW as long as the stability is not compromised. Reinforcement of the BIW is recommended but not required provided the BIW is sufficiently stable.

To ensure a clear view of dummy kinematics, fixed roofs above the front row seats shall be cut away between the cant rails and rearwards of the windscreen surround. Reinforcement shall subsequently be applied laterally across the BIW. Vehicles with removable roofs, panels or movable sunshine roofs shall be tested without the roof or with them in the open position. The windscreen shall be removed and sufficient reinforcement around the frame/periphery shall be provided.

Sufficient spacers shall be fitted in the gaps between the struck side (B-pillar or other structure) and passenger seat frame, the passenger seat frame and centre console to stabilise the front passenger seat. This represents the behaviour of the struck side seat and centre console due to crash induced intrusion and deformation. The spacer shall support the full height of the centre console but does not need to be made from a single piece of foam. It will be necessary to cut the seat cover and foam to access the frame, an example how this can be done is shown in the picture below. The spacers shall have the stiffness characteristics from expanded polypropylene (EPP60) or stiffer with compression properties of about 340KPa for 25% of compression (determined according to ISO 844).

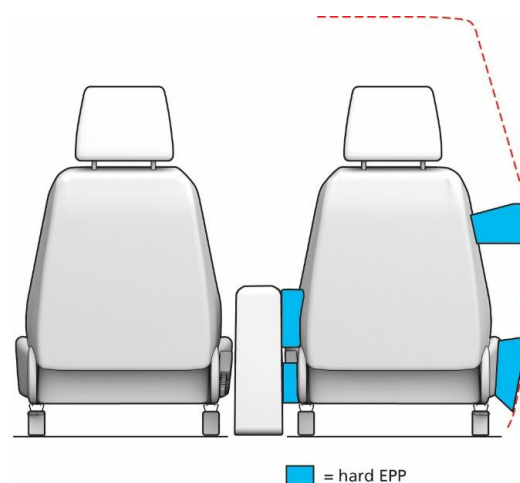

Figure 6: Example of seat spacers viewed from rear

Interior components required for testing will include, but are not limited to:

- Driver and passenger front seats.
- Full tunnel/centre console components consisting of the full tunnel trim, hand brake assembly, gear lever assembly and storage compartments.
- Full fascia assembly consisting of the fascia, steering column and steering wheel. Infotainment systems may be omitted if appropriate.
- Seat belt/pretensioner and anchorage attachments.
- Struck side internal door trim assembly (if doors installed).

If fitted, the struck side door trim shall be painted white (or similar) to contrast with the passenger's seat. The head restraint on the unoccupied seat may be removed in order to get a better view of the grid board and excursion lines.

3.5.5 Main Loadcases

Head excursion zones	Capping	Red		Orange	Yellow	Green
		≤125mm	>125mm			
With countermeasure	0	0.5	1	1.5	2	2
Without countermeasure		0	0	0.5	1	2

In case of head excursion in the capping zone, both far side loadcases are capped.

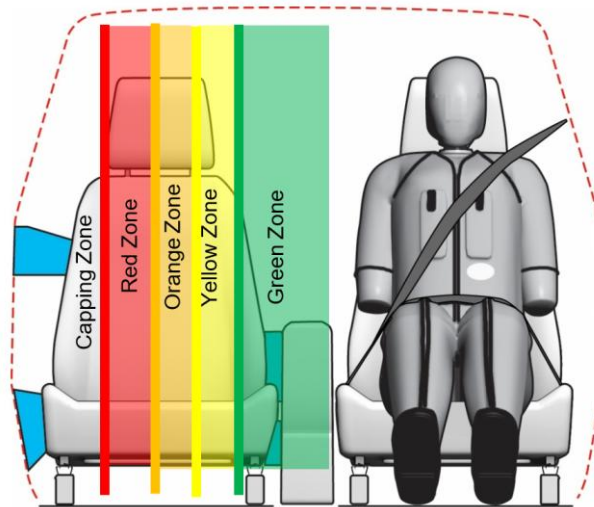

Where any of the limits below are exceeded, the test in which it occurred will be capped.

Criterion		WorldSID 50 th capping limits	
Head	HIC15 (with direct contact)	-	700
	Resultant 3ms acceleration	g	80g
Upper neck	F_{tension}	kN	3.74
	M_{flexion} Mx MxOC	Nm	248
	$M_{\text{extension}}$ negative MyOC	Nm	50
Lower neck	F_{tension}	kN	3.74
	M_{flexion} Mx base of neck	Nm	248
	$M_{\text{extension}}$ negative My base of neck	Nm	100
Chest	Lateral compression	mm	50
Abdomen	Lateral compression	mm	65

3.5.5.1 Main loadcase details

Pulse	Angle	Seat setting	Reference ID
AE-MDB	75°	Section 2.2.1	FS_AEMDB_75_x-ref_z-ref_50M_Sim_1
Pole	75°	Section 2.2.1	FS_Pole_75_x-ref_z-ref_50M_Sim_1

3.5.6 Robustness loadcases

Pulse	Robustness	Excursion criteria	Total points
AE-MDB	ALL AE-MDB robustness loadcases	Equal or not increased by more than one colour zone compared to the main loadcase of the corresponding pulse and can not be red	2
Pole	ALL Pole robustness loadcases		2

In addition to the far side main loadcases, the countermeasure robustness will be evaluated using different seating positions. Where the head excursion in the main loadcase is in the red zone, no rewards will be given for robustness in that loadcase. No capping limits or modifiers are applied.

Vehicles without a far side countermeasure will only qualify for robustness rewards when the head excursion in the corresponding sled test scenario remains within the green zone.

3.5.6.1 Robustness loadcase details

Pulse	Angle	Seat setting	Reference ID
AE-MDB	60°	Section 2.2.1	FS_AEMDB_60_x-ref_z-ref_50M_Sim_1
	75°	Position as 2.2.1 then put in highest	FS_AEMDB_75_x-ref_z-high_50M_Sim_1
	90°	Section 2.2.1	FS_AEMDB_90_x-ref_z-ref_50M_Sim_1
	90°	Position as 2.2.1 then put in highest	FS_AEMDB_90_x-ref_z-high_50M_Sim_1
Pole	75°	Position as 2.2.1 then put in highest	FS_Pole_75_x-ref_z-high_50M_Sim_1
	90°	Section 2.2.1	FS_Pole_90_x-ref_z-ref_50M_Sim_1

Where the angle of the selected robustness loadcase is different than 75°, the buck has to be rotated accordingly.

To put the seat in the highest position where required, use the following procedure:

- Put the seat as into the seat position as per Section 2.2.1
- Adjust the seat height to the highest position by applying the seat control that primarily moves the seat vertically. (Remark: it is accepted that H-point x position changes).

If setting the seat to the highest position causes contact between the WorldSID head and roof, the seat position should be lowered as little as possible to avoid initial contact between the head and the roof.

If the vertical adjustment causes implausible seatback angles (e.g. outside of the design limits of the dummy, in a position where the head level requirements can not be met), the seatback angle shall be adjusted to the seatback angle in the reference position or the closest notch. This can be done by readjusting the backrest to the original backrest position.

If initial contact occurs between the steering wheel (column) and the WorldSID, the steering wheel column shall be slightly adjusted, just to avoid the initial contact with the dummy. When needed, the seat can be adjusted fore/aft (x-position) as little as possible to avoid initial contact between steering wheel (column) and dummy.

3.5.7 Occupant to occupant protection

Where a vehicle is equipped with a countermeasure against occupant to occupant contact, its efficacy will need to be demonstrated in the official Euro NCAP pole impact test with the use of two 50th percentile WorldSIDs. The requirements are detailed see Section 0.

Where a vehicle is NOT equipped with a countermeasure against occupant to occupant contact, no points shall be awarded.

4 POSTTEST ASSESSMENT & INSPECTION

4.1 After test

Immediately after the test, check that none of the doors, boot lids and any movable roofs have opened or partially opened during the test. Where this is the case photographic evidence shall be obtained and provided in the test report.

Struck side doors handles shall be immediately covered with tape to prevent inadvertent opening. Reference measurements shall be taken between the door skin and aperture to ensure that the door has not move or been disturbed between the test and inspection.

Refer to the Euro NCAP Post Crash protocol for further details of all posttest assessments and provide all required information in a Post crash report.

4.1.1 Dummy removal

Before dummy removal, refer to the Post Crash protocol for seat belt buckle unlatching.

Do not move the driver or passenger seats, try to remove the dummies. If the dummies cannot be removed with the seats in their original positions, recline the seat back and try again. Note any entrapment of the dummies. If the dummies can still not be removed, try to slide the seats rearwards on their runners. If the dummies can still not be moved, the seats may be cut out of the car. Record the method used to remove the dummies.

4.1.2 Rollover

Rollover requirements	
Triggering of HPD	The vehicle manufacturer must provide evidence showing that the vehicle can both sense rollover and that the side curtain HPD is deployed as a result. Functionality of rollover triggering shall be demonstrated with a full scale rollover dynamic test which may be selected by the OEM.
HPD inflation	<p>During the HPD measurements, after airbag deployment, detailed in Section 4.1.3, the laboratory will check that the deployed curtain airbag remains inflated and maintains sufficient pressure for at least 6 seconds to provide head impact protection.</p> <p>Where the laboratory check cannot be performed or there are doubts regarding inflation, functionality of rollover countermeasures shall be demonstrated with one of the following:</p> <ul style="list-style-type: none">HPD internal pressure retention of 50% for a minimum of 6 seconds – C-NCAP 2024. Data must include pressure vs time output.Compliance with FMVSS 226.

Both of the above requirements must be met in order to receive rewards for rollover protection, no partial rewards will be given. Where the HPD attracts the incorrect airbag deployment modifier in either the AE-MDB or pole impact tests, no rewards will be given for rollover protection.

Vehicles with asymmetric curtain HPDs will be required to demonstrate protection on both side of the vehicle in order to gain rollover rewards.

4.1.3 Side head protection airbag evaluation (HPD)

HPD requirements	
Coverage area	<p>Vehicles equipped with side impact head protection devices (HPD) curtain, seat mounted or any other, will have the inflated energy absorbing areas evaluated by means of a geometric assessment. The HPD must provide protection for a range of occupant sizes in both the front and the rear seat rows on both sides of the vehicle.</p> <p>If the vehicle is equipped with movable rear seats the seat shall be set to the most rearward position. If there is a third row of fixed seats, these will be included in the assessment unless they are per manufacturers' recommendation not suitable for adult occupancy (handbook).</p> <p>The coverage area is detailed in Section 4.1.3.1.</p>
Symmetrical protection	<p>Where the airbags differ between the left and right hand sides of the vehicle, the airbags on both sides of the vehicle will be evaluated and the assessment will be based upon worst performing side. All areas of the airbag, both front and rear, will be evaluated and the assessment will be based upon the worst performing part of any of the airbags.</p>
Exclusions	<p>The head protecting airbags should cover all glazed areas within the defined zone up to the edge of door daylight opening (FMVSS201) where it meets the roofline, B-pillar, C-pillar and door waistline. Seams in the airbag will not be penalised provided that the un-inflated area is no wider than 15mm. Any other areas where the airbag layers are connected will not be penalised provided that the surrounding areas are inflated, and any un-inflated areas are no larger than 50mm in diameter or equivalent area or the sum of the major and minor axes of individual areas does not exceed 100mm. In the case that the un-inflated area would be larger than described above, the OEM shall provide data to demonstrate sufficient energy absorption is guaranteed.</p> <p>Where a vehicle is fitted with a third row of seats where the full seat assembly can be moved/stowed into the floor, the third row (only) will be excluded from the assessment. Seats with only folding seatbacks are NOT exempt.</p>

All of the above requirements must be met in order to gain any rewards for HPD protection, no partial rewards are given.

Where a vehicle does not offer sufficient protection, a penalty shall be applied to the overall pole impact score as defined in Section 0. Any vehicle that does not provide a head protection device covering the front and rear seat positions on both sides of the vehicle will also attract this modifier.

4.1.3.1 Side head protection device evaluation

Using the location of the H-point as measured in Section 2.3 for the front seating position, calculate and record the corresponding 5th female and 95th male head centre of gravity positions for the front seat to determine the corners of the head CoG box:

4.1.3.2 5th female Head CoG:

$$X_{CoG,5th} = H\text{-point}(X) + 126 - \text{seat travel } 5^{th}\text{-}50^{th}$$

$$Z_{CoG,5th} = H\text{-point}(Z) + 594$$

4.1.3.3 95th male Head CoG:

$$X_{CoG,95th} = H\text{-point}(X) + 147 + \text{seat travel } 50^{th}\text{-}95^{th}$$

$$Z_{CoG,95th} = H\text{-point}(Z) + 693$$

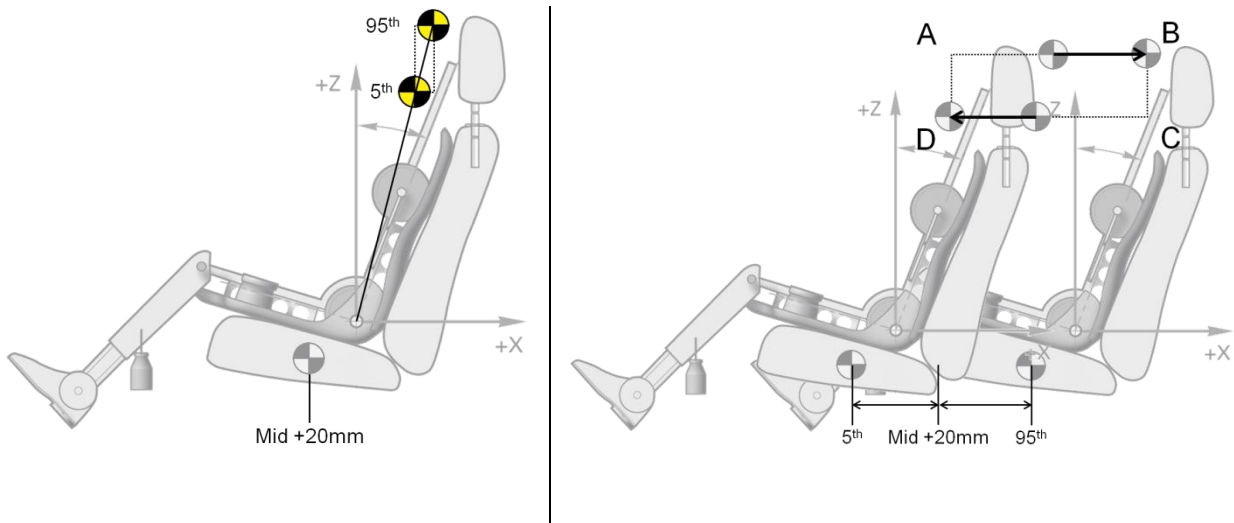

Figure 7: HPD zone front seat row

The four corners of the Head CoG box are:

	X-position	Z-position
A	$X_{CoG,5th}$	$Z_{CoG,95th}$
B	$X_{CoG,95th}$	$Z_{CoG,95th}$
C	$X_{CoG,95th}$	$Z_{CoG,5th}$
D	$X_{CoG,5th}$	$Z_{CoG,5th}$

The seat travel for the 5th and 95th positions will be required from the vehicle manufacturer in Technical Bulletin CP 002 but verified by the laboratory. Where differences exist, the worst case seat positions shall be used.

Using the location of the H-point for the rear seating position as measured for the Rear Whiplash protocol, calculate and record the corresponding head centre of gravity positions in the most forward and rearward seating positions, see Figure 8:

4.1.3.4 5th female Head CoG in most forward seating position:

$$X_{CoG,5th} = H\text{-point}(X) + 126 - \text{remaining seat travel (if applicable)}$$

$$Z_{CoG,5th} = H\text{-point}(Z) + 594$$

4.1.3.5 95th male Head CoG in most rearward seating position:

$$X_{CoG,95th} = H\text{-point}(X) + 147 + \text{remaining seat travel (if applicable)}$$

$$Z_{CoG,95th} = H\text{-point}(Z) + 693$$

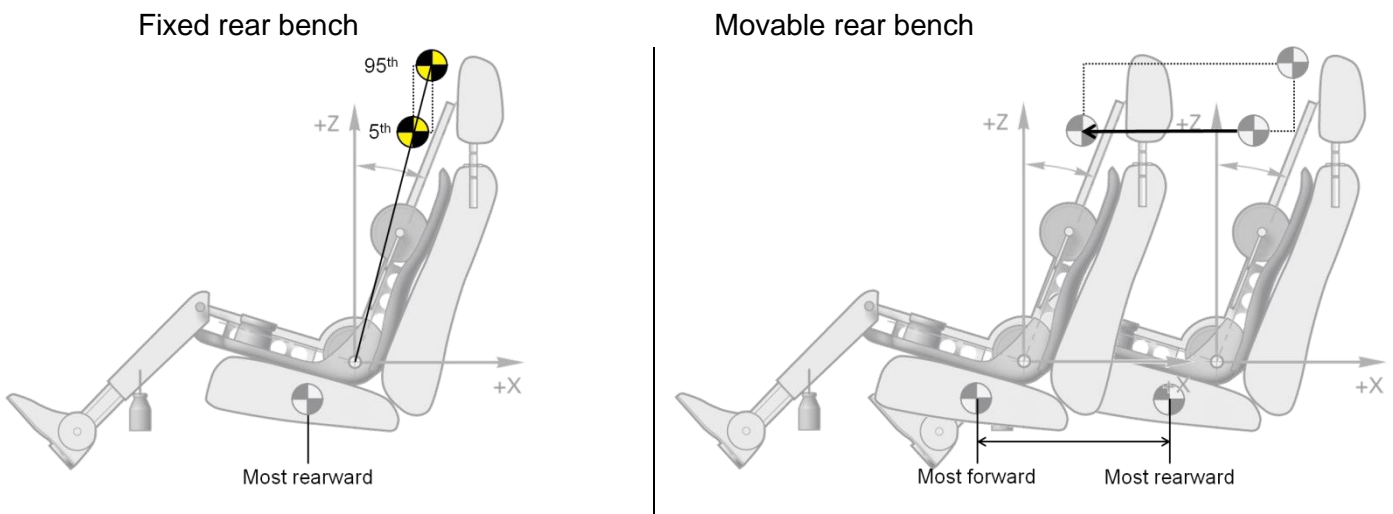

Figure 8: HPD zone rear seat row(s)

The side curtain evaluation zone is defined as a rounded rectangle around the head CoG box at a distance of 82mm from the upper and fore/aft edges and 52mm below the bottom edge. It is acceptable for the 82mm radius in the lower corners of the airbag to be cut-off at 52mm below the CoG box. The zone shall be constructed parallel and perpendicular to the ground reference level, see Figure 9.

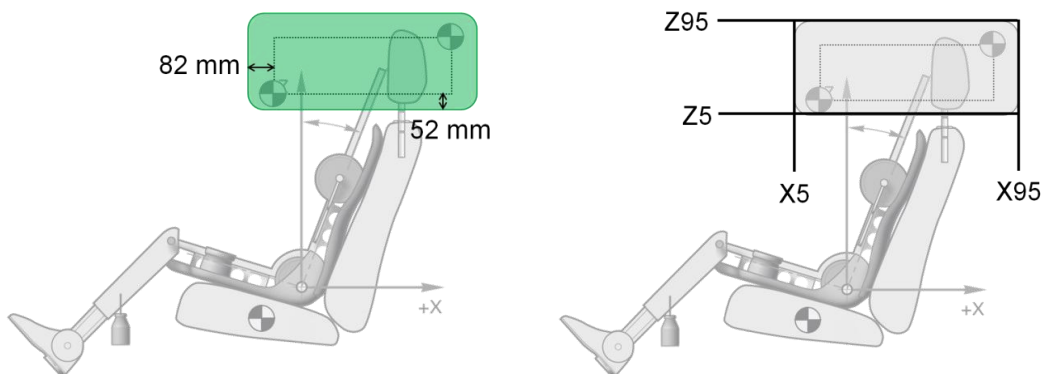

Figure 9: HPD assessment zone

After the pole test, deploy the head protection device on the non-struck side of the vehicle. Make sure that the airbags are identical on both sides of the vehicle. Where this is not the case, the assessment must be performed on both sides.

Inflate the airbag to the pressure recommended by the OEM.

Project the assessment zone onto the inflated airbag for front and rear seating positions using the measurements marked/recorded above.

4.1.3.6 Seat mounted head protection devices

Based on the head CoG paint mark on the airbag, mark the HPD assessment zone defined as a rounded rectangle extending 95mm forward, 90mm rearward, 120mm upward and 115mm downward on the flattened airbag.

When the paint mark cannot be used, the OEM needs to supply Euro NCAP in-house data for the Side Airbag Head Protection Evaluation.

Evaluate coverage area of the airbag(s), record and check the dimensions of any joined, stitched or seamed areas, see Figure 10.

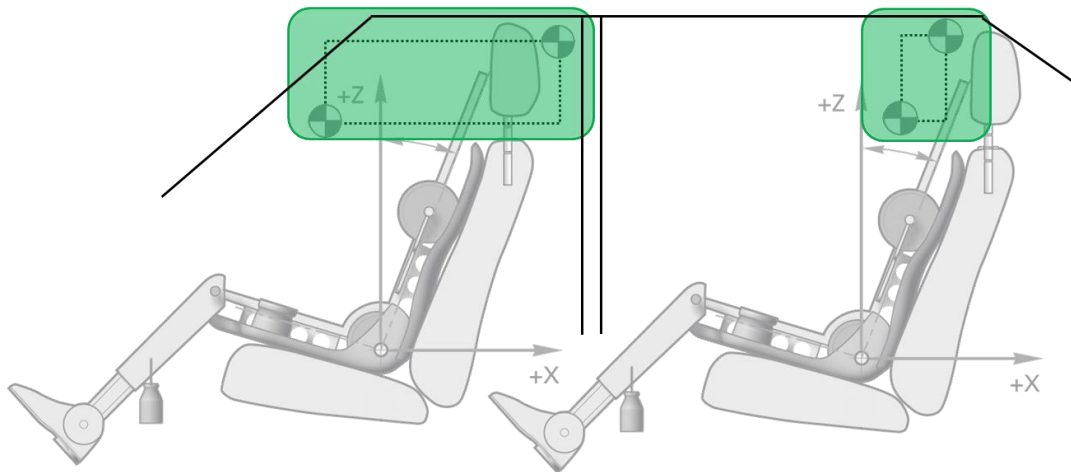

Figure 10: HPD assessment zones

4.1.4 Occupant to occupant protection

Dual occupancy test requirements	
No occupant to occupant interaction	<p>The heads of both the driver and passenger dummies will be evaluated. Upper neck and shoulder forces for both dummies must be reported. Interaction will be determined from the high-speed film with either evidence of direct contact or where the head lower performance limits (HIC or 3ms) are exceeded.</p> <p>Any direct contact between the far side occupant's head and any part of the nearside occupant will be assessed regardless of whether the limits in Section 3.4 have been exceeded or not. For example, if an inflatable countermeasure allows the far side occupant's head to contact the driver, the peak resultant acceleration trace and/or the high-speed film will be used to identify head contact.</p>
Symmetrical protection	<p>Countermeasures must offer equivalent levels of protection in dual occupancy scenarios regardless of which side of the vehicle is impacted. Where a countermeasure is asymmetric, the OEM must provide evidence to show that it provides protection when impacted on both sides. The following methods are permitted:</p> <p style="padding-left: 40px;">A full scale, dual occupancy test impacting the passenger side of the vehicle</p> <p style="padding-left: 40px;">Numerical simulations.</p> <p>In both cases, the front row of seat shall be positioned to that of the AE-MDB test. The HCz assessment window is not applied in this case.</p>
Robustness head coverage zone (HCZ)	<p>A countermeasure against occupant interaction must be able to protect a range of occupant sizes in different seating positions.</p> <p>Protection must be provided in a rounded rectangular area between the passenger head CoG in the dual occupancy pole test position and forwards up to the driver pole impact test position plus an additional 82mm border front and rear (half head diameter). In the vertical direction, the zone is 120mm upwards and downwards of the CoG. See Figure 11.</p> <p>The following shall be noted:</p> <ol style="list-style-type: none"> a) Where countermeasures utilise inflatable systems, the protection zone is measured on a flattened countermeasure using the passenger's head paint mark on the countermeasure from the dual occupancy pole impact test. This will be evaluated during the vehicle inspection. b) It may be necessary to measure the coverage area using an inflated airbag. For example, using a flattened airbag may not be suitable if the shape/orientation of the inflated area cannot be flattened. This will be evaluated during the vehicle inspection. c) In some cases, the countermeasure may offer protection in the requested zone without fully or partially covering the protection zone. In this case, the robustness of occupant to occupant interaction avoidance in the requested protection zone must be clearly demonstrated to Euro NCAP by the manufacturer. <p>This must be done with in house, full scale test data from an equivalent occupant to occupant pole test where the passenger seat is in the position presenting the highest risk of head contact. A different test set-up may be necessary to show that the systems works for different statures within the protection zone, e.g. a different seat position.</p>

All of the above requirements must be met in order to gain any rewards for O2O protection, no partial rewards are given.

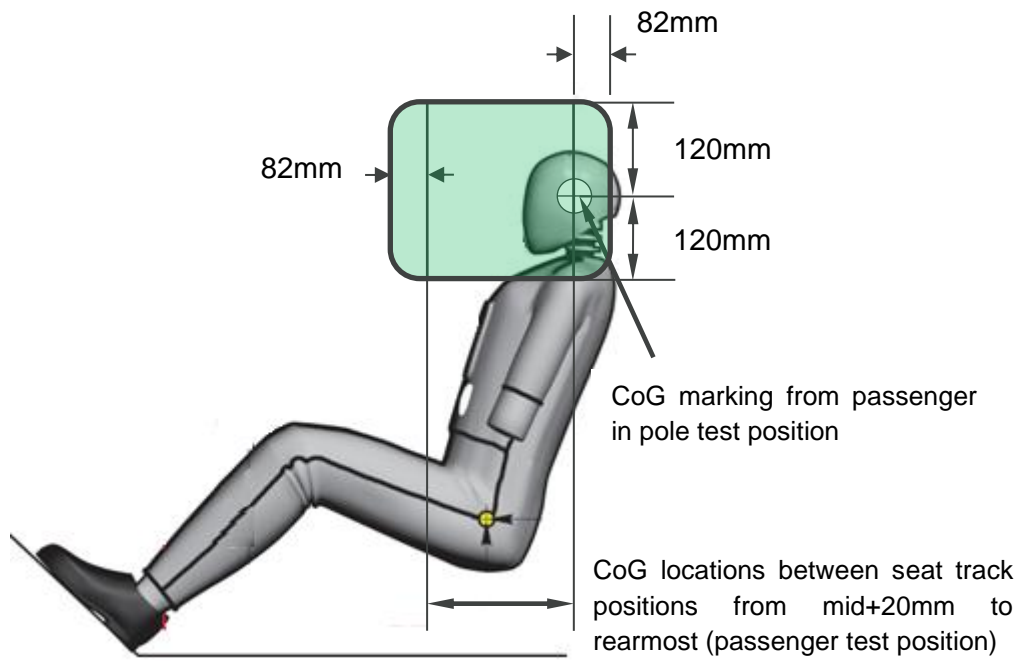

Figure 11: Far side protection zone

4.2 Inspection

After testing has been completed Euro NCAP will perform a vehicle inspection where scoring modifiers can be applied.

4.2.1 AE-MDB & Pole occupant modifiers

The modifier penalties mentioned in the table below are defined as a percentage of the maximum body region score for each dummy, in each loadcase and are applied to that body region. Further details regarding the modifiers and how they are applied to the rating can be found in Technical Bulletin CP 007.

Front Occupant	Modifiers	Criterion	Modifier score
Head & neck	Direct contact with pole	Inspection	capping
	DAMAGE	DAMAGE \geq 0.47	monitoring
	Incorrect airbag deployment	Inspection	-20%
Chest	Shoulder load	\geq 3.0kN	-100%
	Viscous Criterion	\geq 1.0m/s	-100%
	Incorrect airbag deployment	Inspection	-20%
Abdomen	Viscous Criterion	\geq 1.0m/s	-100%
	Incorrect airbag deployment	Inspection	-20%
Pelvis	Incorrect airbag deployment	Inspection	-20%

Rear child occupants	Modifiers	Criterion	Modifier score
Head	Restraint	Inspection	-100%
Q dummy test score	CRS to vehicle attachment	Inspection	-50%

4.2.2 Test modifiers

The modifier penalties mentioned in the table below are defined as a percentage of the maximum adult occupant test score for each loadcase.

Test penalties	Modifiers	Criterion	Modifier score
HPD – applied to pole impact test score only	Curtain airbag measurement	Zone measurement	-10% per row
Rollover – applied to pole impact test score only	Curtain airbag inflation or no rollover sensing	Inspection	-20%
Door opening		Inspection	-5%
Door detachment	Structural detachment	Inspection	-100%
Restraint failure		Inspection	-100%

4.2.3 Far side occupant modifiers

The modifier penalties mentioned in the table below are defined as a percentage of the maximum adult occupant test score for the far side loadcase.

Front Occupant	Modifiers	Criterion	Modifier score
Pelvis	$F_{\text{pubic symphysis}}$	2.8kN	-25%
	$F_{\text{y lumbar}}$	2.0kN	
	$F_{\text{z lumbar}}$	3.5kN	
	$M_{\text{x lumbar}}$	120Nm	